



LR28

larger-format line-array module

user's manual

Featured models:

LR28

LB28

LR28B



evolutionary audio solutions™

Table of contents

1	Introduction	3
2	Important safety instructions and precautions	4
3	Installation	5
4	Rigging components	6
5	Array configurations	10
	Cabinet connections	10
	GRD28 options	12
	GRD28B options	13
	GRD28 hoist options	14
	GRD28B hoist options	15
	Fly mode array assembling and hoisting	16
	Compression style array assembling and hoisting	18
6	Service and support	23
7	CE declaration of conformity	25



1. Introduction

Dear customer,

Congratulations on your purchase of an Alcons Audio LR28 line array loudspeaker and thank you for your confidence in Alcons products. We are very honoured to welcome you to the growing family of Alcons ambassadors!

For your safety, please read the Important safety instructions and the precautions section before rigging a loudspeaker array.

General features

The LR28 has the following features:

A unique seamless arrayability up to/beyond 20kHz.

Symmetrical 80°/110° dispersion in the non-coupling plane.

Ultra-high-performance line-array system for even the largest applications.

Non-compressed 1:1 HiFi-quality sound reproduction.

Intuitive predictable linear response behavior and identical tonal balance at any SPL.

14" pro-ribbon HF section with exceptional intelligibility and "throw".

Maximum dynamic headroom reserve with up to 90% less distortion.

Fully coherent and symmetric pattern control in horizontal and vertical plane.

SIS™ pre-wired for very high system damping and further reduced distortion.

All Neodymium drivers for excellent performance-to-weight ratio.

LR28 rigging features

The trapezoidal cabinet is fitted with integrated mounting hardware, enabling angle-setting on the cabinets, without lifting the array, resulting in safer and faster set-up with minimal handling. The rigging system supports different modes of array assembling and has a working load limit of 24x LR28, 32x LB28 or 16x LR28B cabinets under 10:1 safety.

Manual

This manual is written in a compact and easy readable way. You can contact Alcons Audio for more in-depth information on different items or situations



2. Important safety instructions and precautions

Read this manual

1. Follow all safety instructions as well as the warning messages.
2. Never incorporate equipment or accessories not approved by Alcons Audio.
3. Read all the related product information before using the system.
4. Work with qualified personnel for rigging the system.
5. Installation should only be carried out by qualified personnel who are familiar with the rigging techniques and safety recommendations stated in this manual.
6. Ensure health and safety during installation and setup.
7. All persons must wear protective headgear and footwear at all times. Under no circumstances personnel is allowed to climb into a loudspeaker assembly.
8. Respect the Working Load Limit (WLL) of third party equipment.
9. Alcons Audio is not responsible for any rigging equipment and accessories provided by third party manufacturers. Verify that the Working Load Limit (WLL) of the suspension points, chain hoists and all additional hardware rigging accessories is respected.
10. Respect the maximum configurations and the recommended safety level.
11. For safety issue, respect the maximum configurations outlined in this manual. To check the conformity of any configuration in regards with the safety level recommended by Alcons Audio.
12. Be cautious when flying a loudspeaker array. Always verify that no one is standing underneath the loudspeaker array when it is being raised or lowered. As the array is being raised, check each individual element to make sure that it is securely fastened to the adjacent element.
13. Never leave the array unattended during the installation process. As a general rule Alcons Audio recommends the use of safety slings at all times.
14. Ensure that the surface is suitable for ground-stacking a loudspeaker array.
15. Do not stack the loudspeaker array on unstable ground or surface. If the array is stacked on a structure, platform, or stage, always check that the latter can support the total weight of the array. As a general rule, Alcons Audio recommends the use of safety straps at all times.
16. When a loudspeaker assembly is deployed in an open air environment, wind can produce dynamic stress to the rigging components and suspension points. If the wind force exceeds 6 Beaufort scale, lower down and/or secure the loudspeaker array.



The exclamation point within a triangle is intended to alert the user to the presence of important operating instructions in the literature accompanying the product.

3. Installation

Unpacking

Carefully open the shipping carton and inspect all the parts. Every Alcons product is thoroughly tested and inspected before leaving the factory and should arrive in perfect condition. If you find any damage, notify the shipping company immediately. Only you, the consignee, may initiate a claim for shipping damage. Be sure to save all packing materials for the carrier's inspection.



4. Rigging components

LR28 loudspeaker

- | | |
|--------------------------|---|
| 1) LR28/ LB28 cabinet | LR28/80° cabinet (drawn) |
| 2) Front coupler | Coupler, lockable with quick release pin |
| 3) Bar handle | Handles in the cabinet ensure easy handling |
| 4) Pin pre-rig transport | Pin holding the cabinet at 0° on the PRRGL28 |
| 5) Signal input/ link | Input/ link for the audio signal |
| 6) Angle frame | This frame holds features for the angle setting and back coupling |
| 7) Pin slider | Black color indicates LR28/80°, green LR28/110° |



4. Rigging components

LR28B loudspeaker

- | | |
|---------------------|--|
| 1) LR28B cabinet | LR28B cabinet |
| 2) Coupler | Rotatable couplers, lockable with quick release pin |
| 3) Bar handles | Handles in the cabinet ensure easy handling |
| 4) Bottom connector | Connection with two holes, enabling a 2,5° splay angle |



4. Rigging components

GRD28

This grid is used to suspend a vertical cabinet array. It features a sliding extender bar and an adjustable foot for stacking. It has a mounting position and through hole for the Teqsa laser/ inclinometer. It has a WLL of 24x LR28, or 32x LB28 cabinets. all points measure 20mm/0.8-in. It is recommended to use 3,25T shackles in any situation and always use two hoists



GRD28B

The GRD28B enables the LR28 line-array modules, the LB28 line-array extension modules, LR24 line-array modules and LR28B line-array bass modules to be flown and ground stacked. The grid can be suspended from multiple hoist options on top of the grid (all points 20mm/0.8-in for 3,25T shackles).



CNVB1828

This bracket is a transition frame to suspend a small LR18 array under a LR28 for down fill applications. It enables a maximum tilt angle of 8° between LR28 and LR18. CNVB1828 is certified for six (6) cabinets LR18.



4. Rigging components

PRRGL28

This wheeled Pre-rig frame is used to transport 4 LR28 or LB28 cabinets. It can also be used as a ground stack base, with optional adjustable **SWFTPRRGL28** feet. It has a 0° or 6° angle arm. The frames can be stored on top of each other, using the wheel recesses. The **SFTCVR4LR28** soft cover is an essential option for the LR28 Pre-rig.

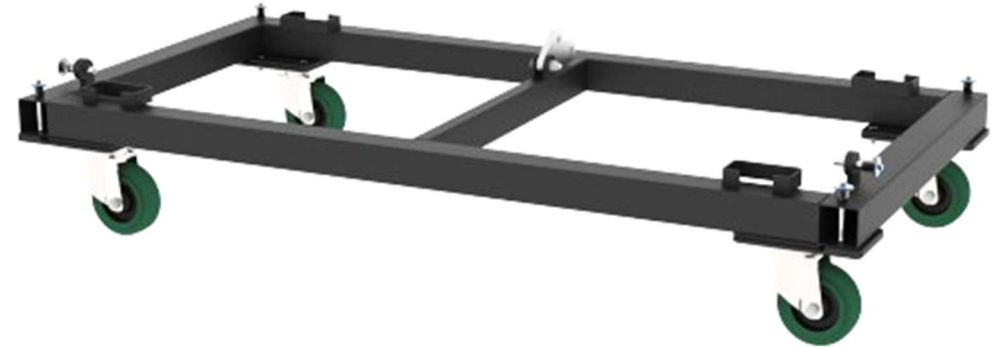

PRRGLR28B

This wheeled Pre-rig frame is used to transport up to 3 LR28B. An optional soft cover is an essential option for the LR28B Pre-rig.

WLFRML28

This frame is used as a pull-back device for compression style flying. The hoist point measures 20mm/0.8-in for a 3,25T shackle. The wheels are detachable. It also ensures, with the wheels mounted, that the bottom cabinet does not get damaged during the optional caterpillar style hoisting.



5. Array configurations

Cabinet connections LR28

Array assembling can be done using two fly options. This is determined by the available space, time or available parts. There are 10 user selectable logarithmic angles, which can be determined by the Alcons Ribbon Calculator™ simulation program. The angles are suitable for both caterpillar and compression style array flying. The angle lay-out is pictured below. The “P” indicates the position of the angle pin, when parking the angle arm. This is done in case of single LR28 cabinet transportation. The general rigging guidelines on the right is also shown at the back of the cabinet.

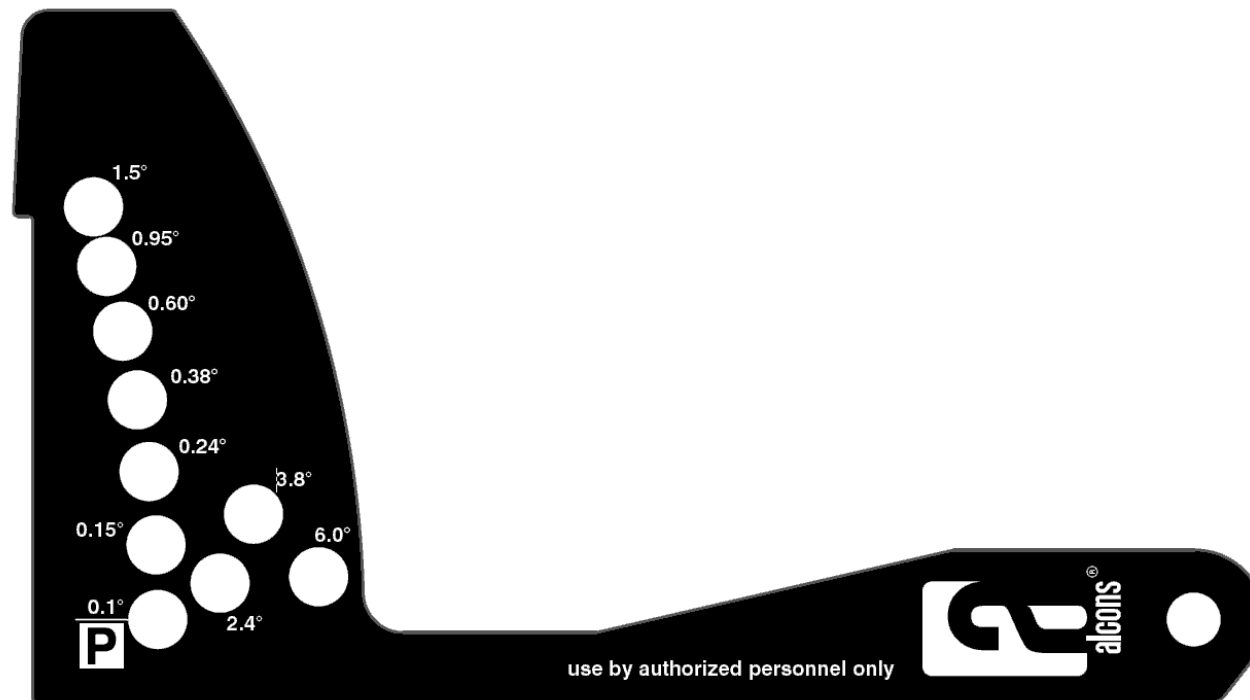

General rigging guidelines

Weight
LR28: 63 kg (139 lb)
LB28: 47 kg (104 lb)
Max. WLL flown:
1550 kg (3418 lb)
Max. 4 cabinets stacked.
Max. 4 cabinets on pre-rig.

⚠
Rigging should be done by authorized personnel only.

Refer to rigging manual for safety / instructions.

Always observe applicable Working Load Limits.

Do not climb loudspeaker assembly!

Angle connecting rod pinning

Fly slot
Compression fly slot

5. Array configurations

Cabinet connections LR28B

LR28B has rotatable couplers, secured/ parked with a quick release pin. This pin is also used to make the connection to the GRD28B or the adjacent cabinet. It is also possible to use the LR28B as a single standing subwoofer. It then stands on its or short side with slider feet.

At the lower end of each bracket, there are two holes, which determines the splay angle or 2.5°. This selection is made before hoisting. Only the front facing side needs to be selected. The back side is set at 0°.

LR28B can be flown in a cardioid setup, using this method. There is a second NL4 Speakon connector mounted in the front grill.

It is advised to use a separate cable hang for the speaker cables, as the NL4 (front rear) Speakon connectors cannot take the entire cable weight.

A second GRD28B, under an LR28B (to enable the connection to an LR28 or LR24 array) is connected with its top rotatable couplers to the 0° holes on the LR28B cabinet. This is also the setup for ground stacking LR28B+LR28/ LR24.

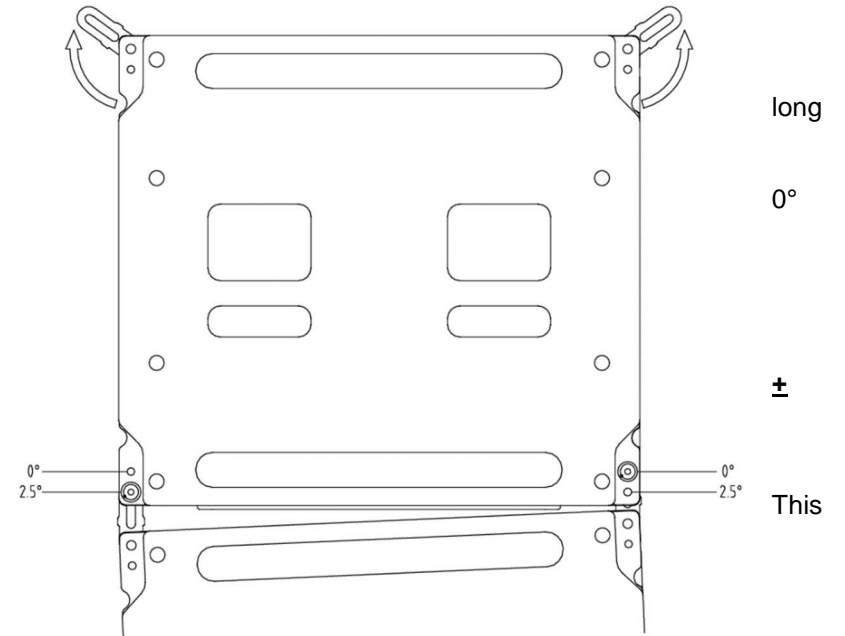

Connection indication GRD28B

L28

-2.7°

L24

0°

stack

GRD28B
 Max. WLL flown: 1550kg (3418 lb)
 Max. 16x LR28B / 24x LR28 / 32x LB28 / 24x LR24
 Max. 4x LR28 / 4x LR24 stacked on GRD28B
 Use 3.25T shackles at all times.
 Rigging should be done by authorized personnel only.
 Refer to rigging manual for safety / instructions.
 Always stay within the applicable Working Load Limits.

Serial number has been removed!

5. Array configurations

GRD28 options

The GRD28 has multiple mounting options. The picture on the right shows the different pick-points for flying an array. Use 3,25T shackles in any situation. The A1 & A6/ A7 marked points are the default hoist points.

It is also possible to use one pick point from the A5 pattern. Use it only for max. 12x LR28 cabinets.

Use 2 hoists at all times.

In case of permanent installation, combine points A2 and A6 to create a stable 3-point hang.

A3 indicates the mounting position of an angle inclinometer. It has a 4xØ4mm; 16.5mm x 108.8mm hole pattern for the Teqsas laser/ inclinometer.

Always use both A4 pins when adjusting the extender bar pick-point A7. The extender bar can also be mounted at the front.

The FCGRD28 flightcase is available as a transport option.

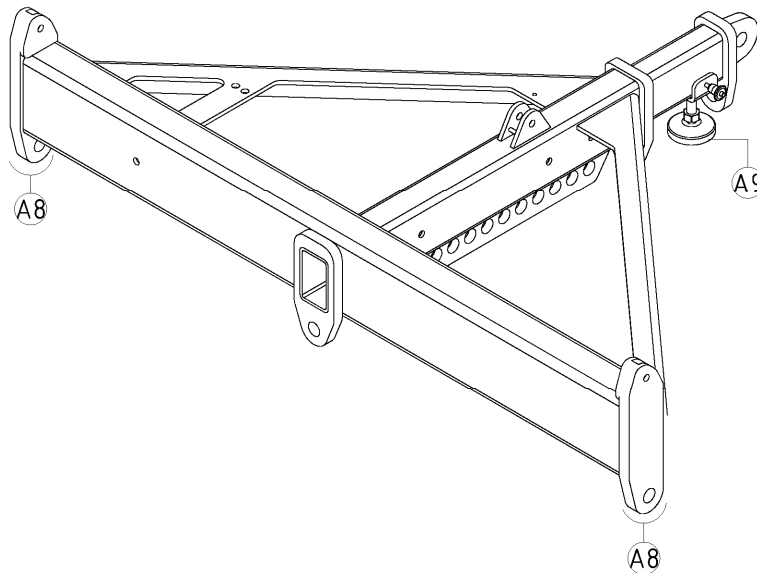
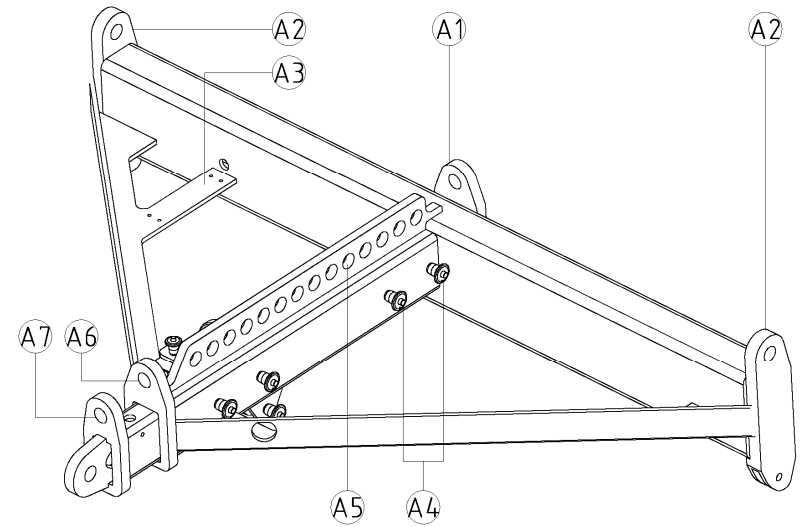

The picture on the left shows the GRD28 in the stacked position. This is used when the PRRGL28 Pre-rig is not suitable. Ensure that there is a stable and flat surface on which to build the stacked array. A max. of 4 cabinets can be stacked in this way. Take off the adjustable foot frame and attach it on the extender bar. Lock it with both small pins. The front of the stacked array will rest on the front A8 stands. The back can be extended and height-adjusted. Assemble the array of 4 cabinets and use the compression fly slot on the angle arm, when adjusting the angles.

5. Array configurations

GRD28B options

The GRD28B has multiple mounting options. The picture on the left shows the different pick-points for flying an array. The grid is used on LR28B in the shown orientation. The A1 & A2 marked points are the default hoist points.

L1 marks the front connection points to a LR28 cabinet. L2 are the LR24 connection points. In both situations, the GRD28B needs to be 180° turned

The 3 holes A5 will hold the connection pin between the LR28 or LR24 angle arm and GRD28B

Use 3,25T shackles at all times

A3 indicates the mounting position of an angle inclinometer. It has a 4x \varnothing 4mm; 16.5mm x 108.8mm hole pattern for the Teqsas laser/ inclinometer.

A8 marks the adapter angle arms in their transport position. They can connect to the bottom connection points on the LR28B and shall be pinned by G1 on the GRD28B. The G2 pins connect to the bottom coupling of a LR28B.

As stated before, the GRD28B needs to be turned 180° to act as the connection between LR28B and LR28/ LR24

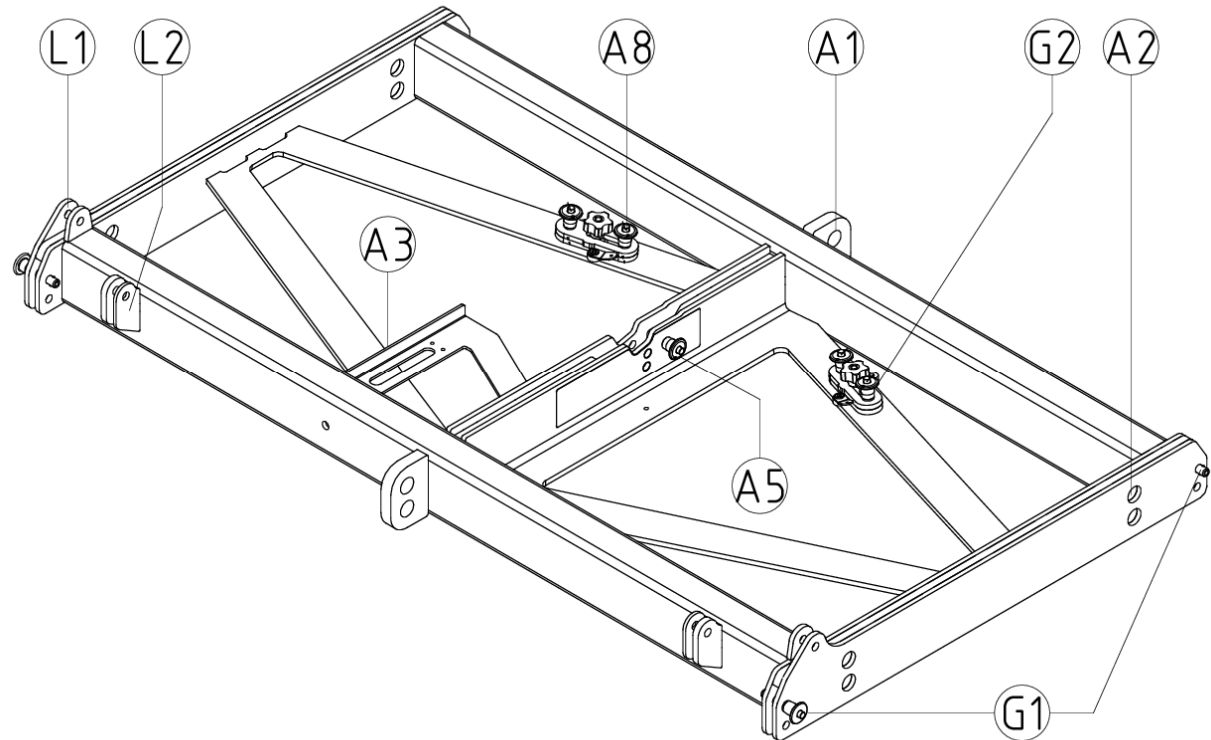

5. Array configurations

GRD28 hoist options

The schematic picture below shows the possible array hang options A-D in fly mode and stack arrangement E&F. As stated earlier, the array angles can be determined through the Alcons Ribbon Calculator™ simulation program. The Centre of Gravity needs to be between the outermost pickpoints at all times!

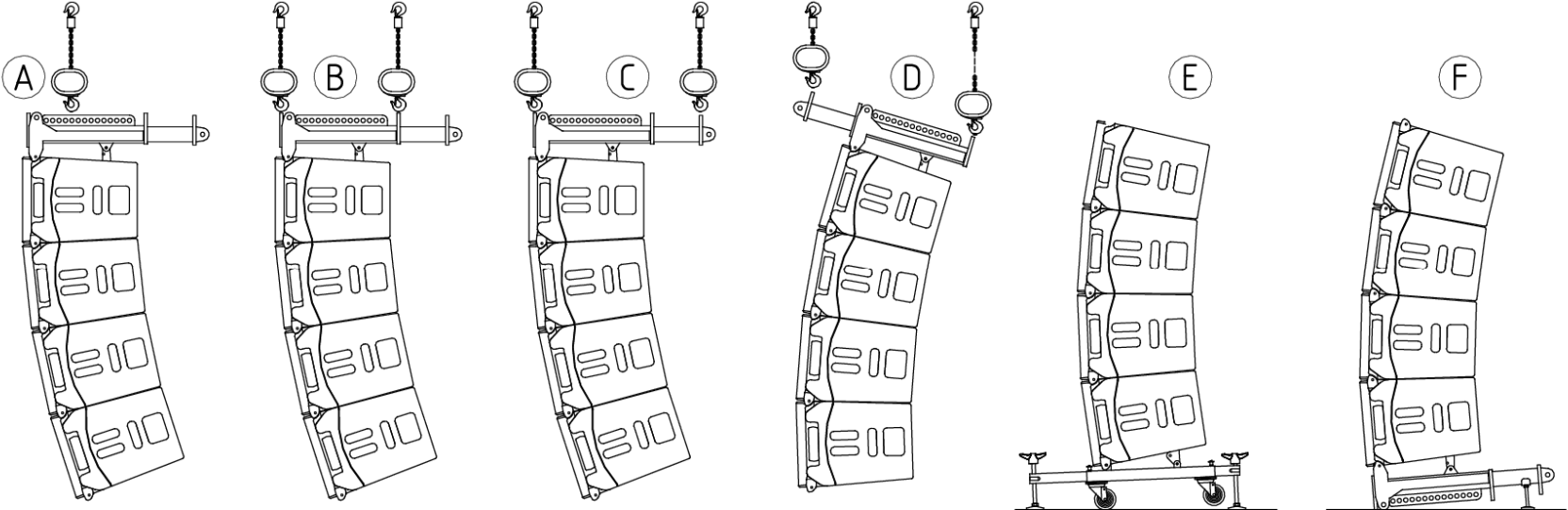

Max. 12x LR28

When stacking (E&F), ensure that the centre of gravity is well within the PRRGL28/ GRD28 support points. The picture below shows the dimensions of the GRD28 at the different extendable positions of the GRD28EXTBR extender bar.

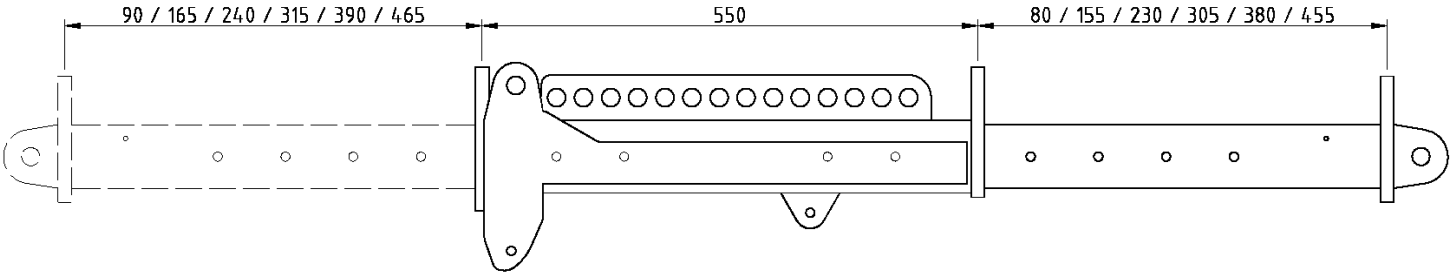

5. Array configurations

GRD28B hoist options

The schematic picture below shows the possible array hang options m-p and stack arrangement q & r with LR28B and LR28/ LR24. Note the chain setup on the back of the array, when flying LR28/ LR24 in compression mode. Attaching LR28/ LR24 to LR28B (flying or stacking) requires a second GRD28B (o). This is due to the fact that the LR28/ LR24 have 3 pick points and LR28B is a 4 pick points set-up. LR28B can therefore be mounted 180° to the adjacent LR18B cabinet, creating a cardioid setup (m). Always attach each pick-point on GRD28B with 2 pins to the top couplers of the LR28B

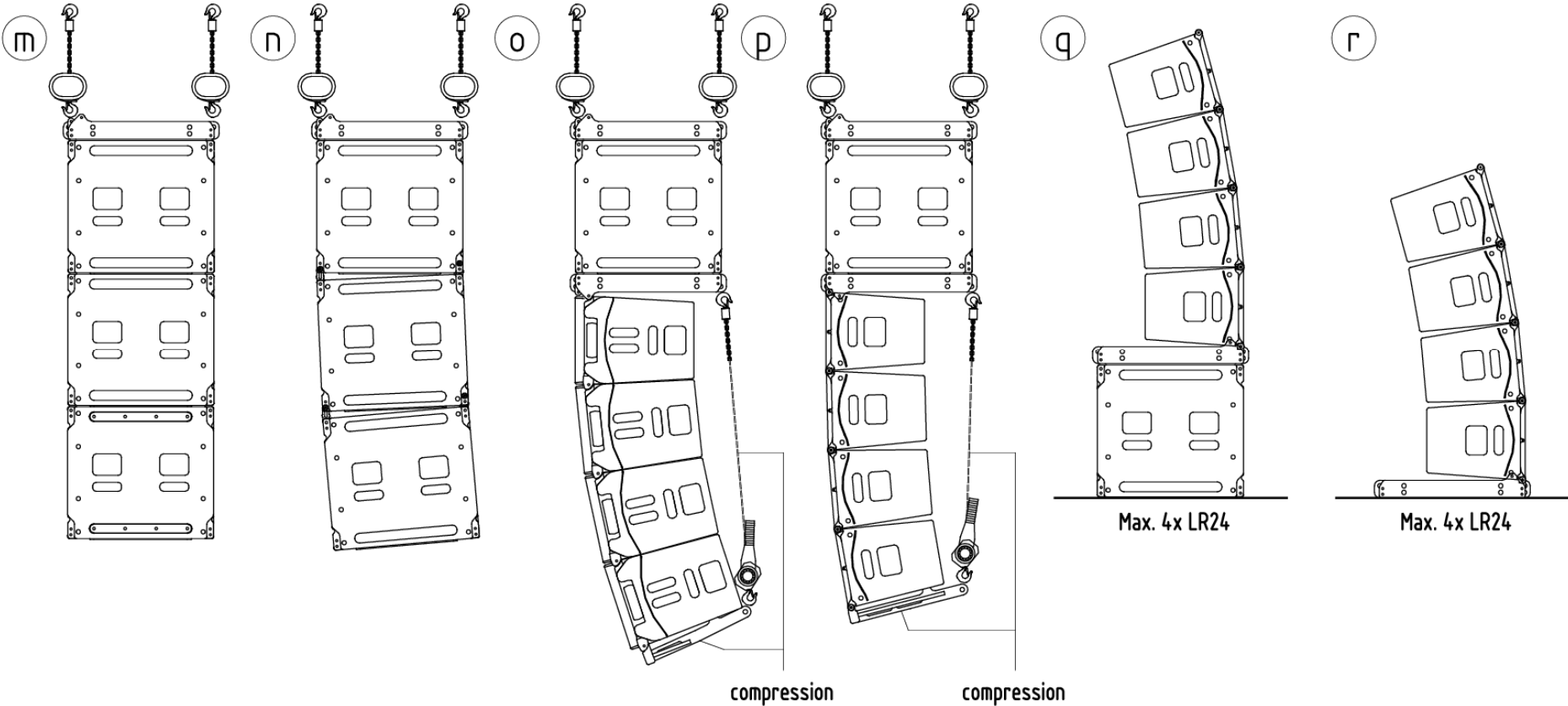

5. Array configurations

Fly mode array assembling and hoisting

Using this mode the LR28 rigging system uses the vertical PRRGL28 pre-rig transporter combined with (non-compression) vertical fly array hanging. This mode uses the top "fly slot" in the angle arm and is best suitable for large 12->24 pcs arrays

The schematic drawing shows the building steps G->L with 2 chain hoists.

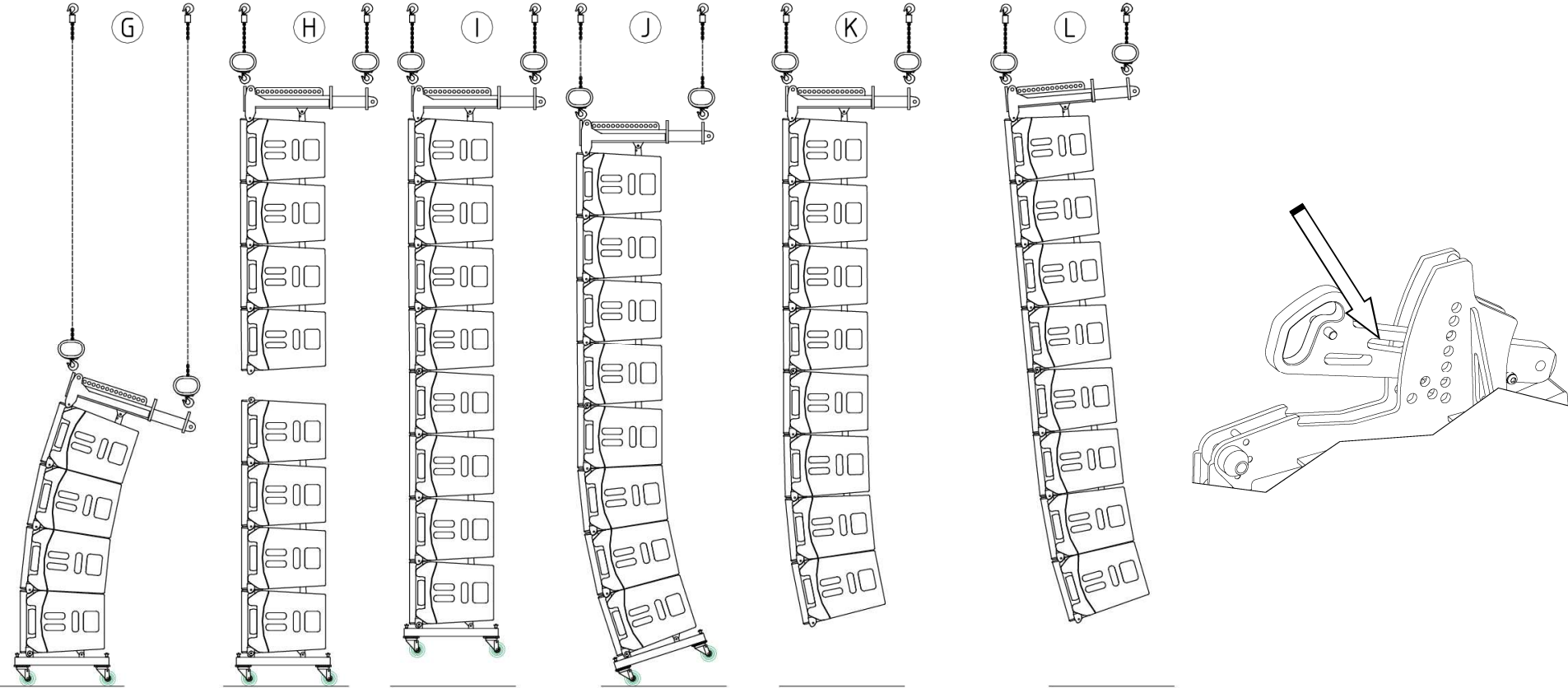

5. Array configurations

Fly mode array assembling and hoisting

The numbers in the picture, correspond with the LR28 rigging components overview pictured earlier.

This flying option uses the PRRGL28 pre-rig transport option. The PRRGL28 (E) transports 4x LR28 or LB28 cabinets in a vertical position. Take off the protective SFTCVR4LR28

Start with the first 4 cabinets. (G). **This is a two man job** Hold each cabinet and remove the angle pin (6) and red buttoned pin (12). Let it rest onto the lower cabinet. Work your way down. Attach the GRD28 and make the angles using the top “fly” slot in the angle arm, with the angle pin (6). Place the red pin (12) in the rubber lined transport hole. Attach GRD28 to the top cabinet. Hoist the first piece of the array. It will stretch out to the correct cabinet angles. When the first array piece is still at working height, speaker cabling can be attached using a hoist sling to the extender bar, to take the cable weight away from the array.

Place the next PRRGL28 under the suspended array (H). Make the connection using the front couplers (2) and angle arm (8). Hoist the 8 piece array (I). Remove the red 0° pins (12) and angle pins (6) from the bottom 4 cabinets. Lower the whole array down and pull it backwards (J). The lower cabinets will compress against each other. The angles can now be set using the angle pins (6) and the top “fly” slot .

Hoist the array. The array will stretch out to the desired angles. detach the PRRGL28 from the array (K). Angle out the array using the back/ front chain hoists (L).

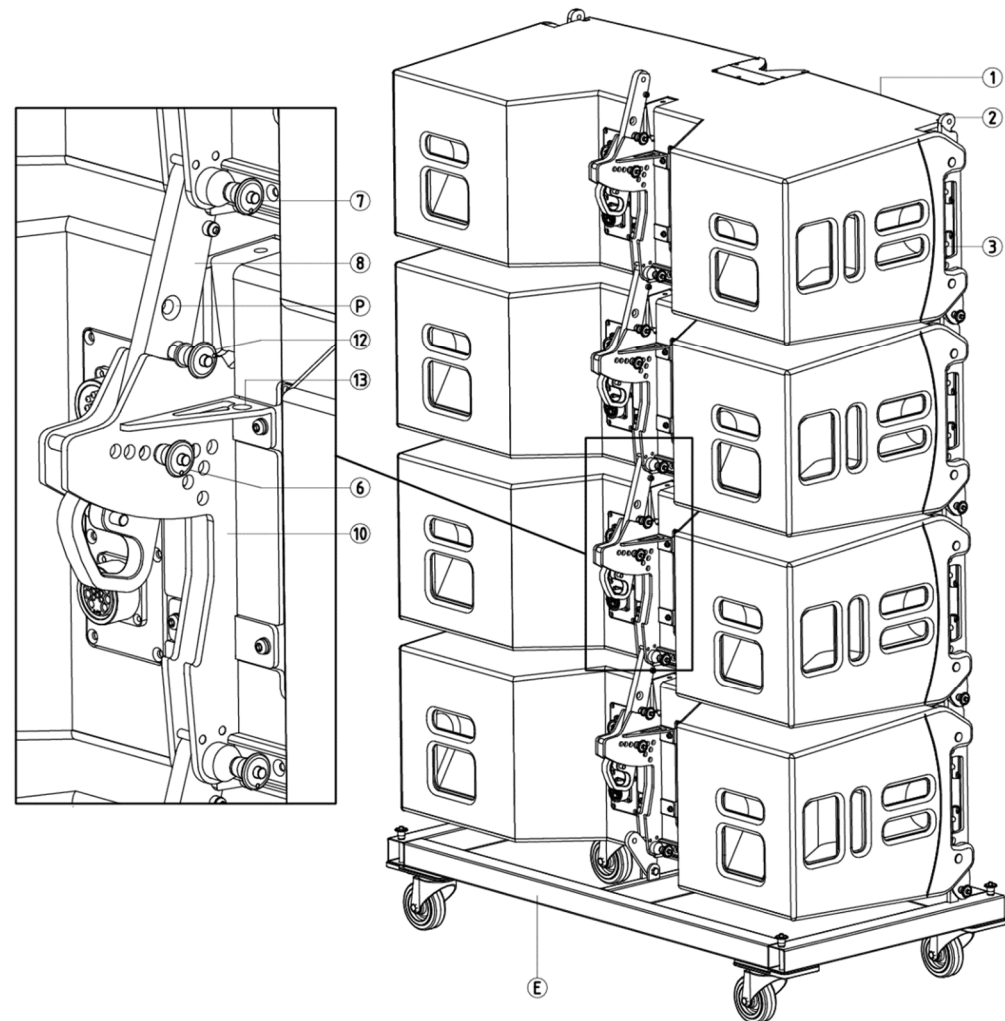

Landing the array

Attach the PRRGL28 pre-rig to the bottom cabinet with the small angle arm at 0°. **This is a two man job.** Land the array and pull the PRRGL28 backwards. The cabinets will start to compress against each other. This will take of the weight of the angle pins (6). Pull the angle pins (6) of the bottom 4 cabinets. Hoist the array back up. The 4 cabinets will stretch out to 0°. Put the red pins (12) into their 0° holes and lower the PRRGL28 onto the ground. Detach the top 4th cabinet on the PRRGL28 from the array. Repeat this for the remaining array pieces.



5. Array configurations

Compression style array assembling and hoisting

This procedure is also used when a LR28B section is used in the array under GRD28B

This flying option is best suited for small 2->12 pcs arrays. The red buttoned pin (12) is crucial in this situation. It ensures that the cabinets (1) will stay in a 0° position. The angle arm can be adjusted while this pin is in position or “0° hole”.

Take the top cabinet angle arm out of the transport position and put the red pin (12) in. Choose the angles by aligning the angle pin (6) with the bottom compression fly slot in the angle arm (8).

The angle setting can be done at the warehouse or on-site. There will be substantial pressure on the red pin (12) when adjusting the angle arm (8).

A slight push/ tilt against the overlying cabinet will also help to ease this pressure. The angle frame (10) has special hardened frame to guide the pin.

When the first cabinets are ready, attach GRD28 to the top cabinet. Ensure that it has the extender bar (B) mounted at the preferred extension. Always use the 2 pins (A4) for each extender bar position

Use a hoist sling to take the weight of the speaker cables away from the cabinet array.

Attach a manual **0,75T lever hoist, with overload protection**, from the bottom shackle position on the extender bar. Be sure to have sufficient chain length. Use an extra safety chain in combination with the lever hoist. **It is not allowed to use a motor hoist.**

Take the PRRGL28 (E) off when the first 4 piece LR28 array is suspended. **This is a two man job.**

Remove all the red buttoned 0° pins (12) and place them in the rubber lined parking holes (13)

Position the next PRRGL28 under the suspended array. Ensure that the angle adjustments are done.

Lower the suspended array to make the three point connection (front couplers + angle arm coupling). You can remove the top red 0° pin to make the back connection easier. When finished and the combined array is suspended in the air, pull out the red buttoned pins (12).

Continue this procedure until full array length is reached.

End with attaching the WLFRL28 (C) under the lowest cabinet. Slide the cabinet connecting pin (7) to the open position. Then hook the frame onto the front couplers (2) and lock with the pins. Now make the connection with the cabinet connecting pin (7) and lock it.

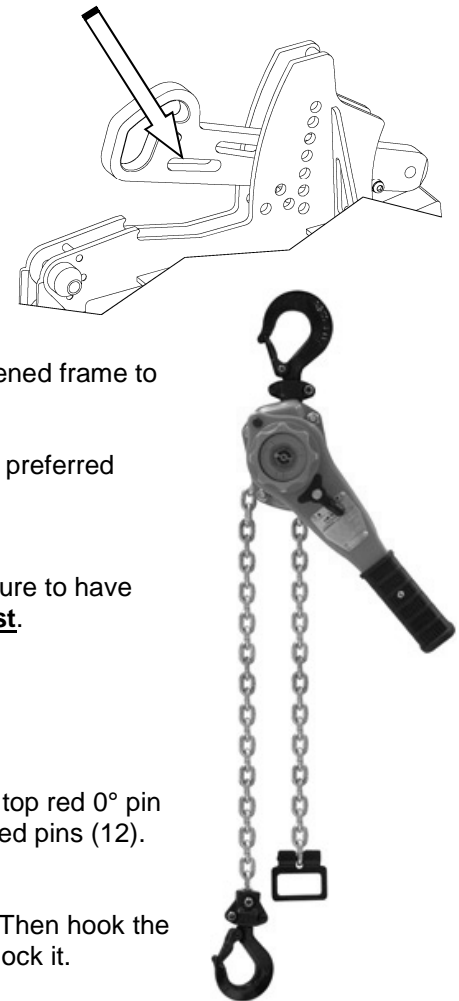

5. Array configurations

Compression style array assembling and hoisting

Start hoisting the (lever) hoist to make the cabinet angles. **This has to be done by an authorised person.** Stop when there is no more slack in the array. This can be checked by pushing the array back and forth and listening for any slack noises in the angle setting frames.



Do not over-compress the array, as this can cause damage to the suspension system !

After the compression stage, the angle of the entire array can now be adjusted. Use an angle inclinometer on the GRD28. The following schematic drawing shows the three hoisting stages with a 4 pcs array.

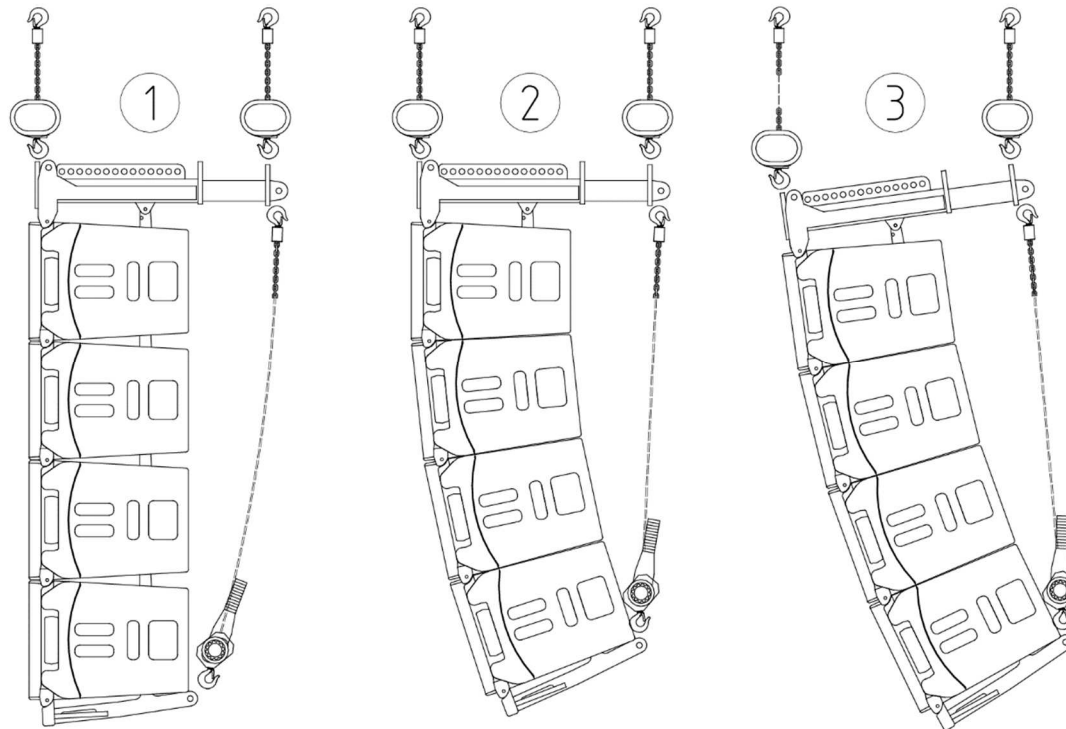

- 1) After array building
- 2) Compression to reach the desired angles
- 3) Array angling

5. Array configurations

Compression style array assembling and hoisting

The schematic picture below shows compression style array hoisting, using two separate chain hoists. This set-up can be done with a max. of 12 cabinets. The first motor hoist is connected to the hole nr. 5 (pattern A5) in the centre of gravity. The second hoist chain has to be attached to the WLF RML28 (C). In this way, the angles can be set using compression and the entire array can be angled.

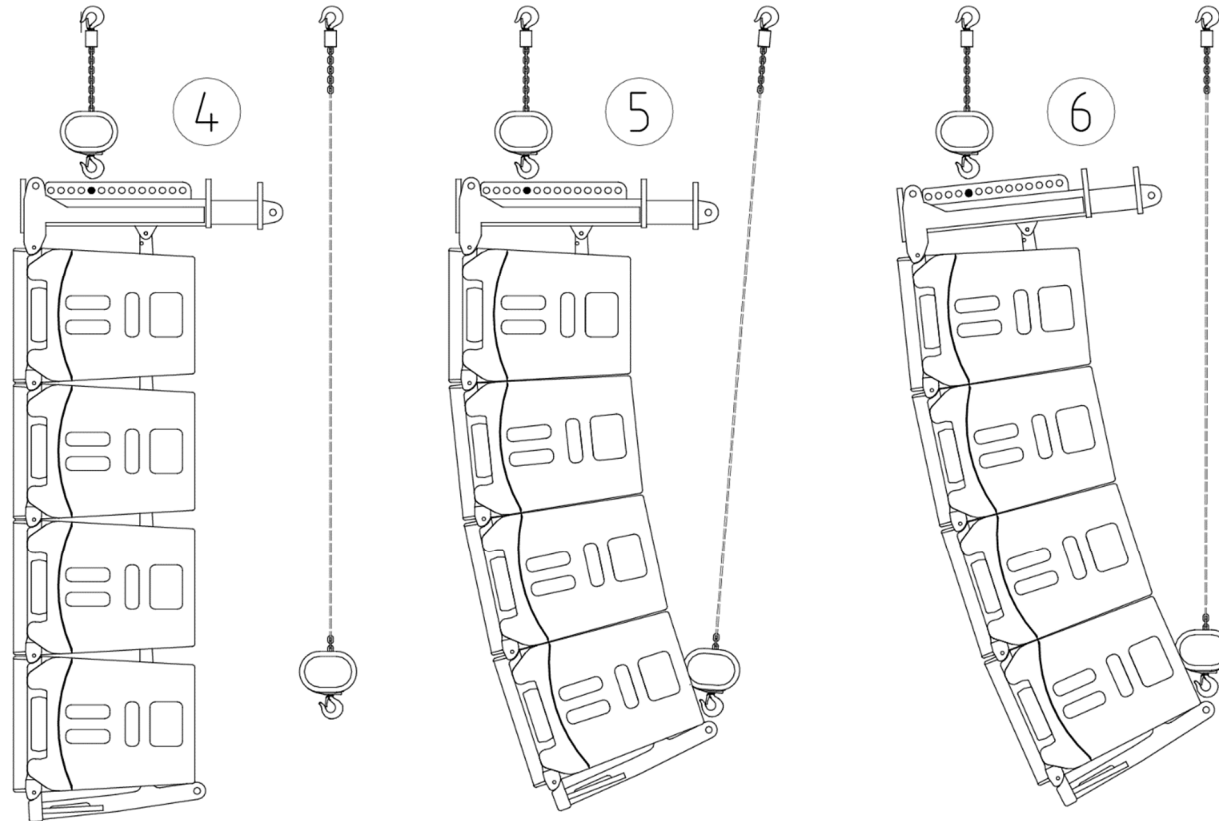

- 4) After array building
- 5) Compression to reach the desired angles
- 6) Array angling

5. Array configurations

Compression style array assembling and hoisting

Landing the array compression style

De-compress the cabinets to 0° by releasing the tension of the lever hoist or back chain hoist. The whole array should now be hanging vertical. Remove the WLFRL28 (C) and attach the PRRGL28 pre-rig (E). **This is a two man job.** The small angle arm has to be attached to the 0° hole to the angle arm connection of the cabinet. See middle picture.

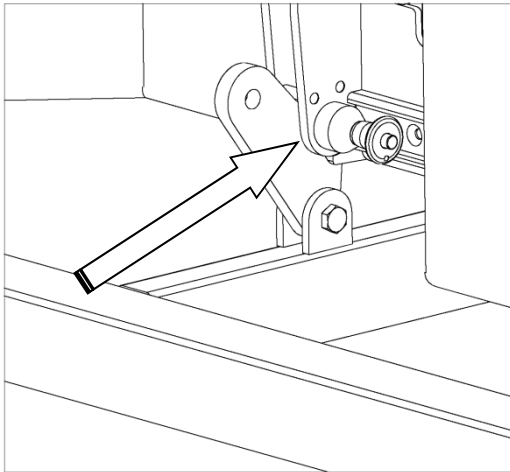

Put the red buttoned pins (12) into the angle arms of the first 4 piece array. Land the PRRGL28 and detach the (front and back) cabinet connection pins above the top no. 4 cabinet on the PRRGL28 and put them into their transport recesses. Continue this procedure. Use the optional SFTCVR4LR28 to protect the PRRGL28 for transport and storage.

5. Array configurations

Using CNVB1828

Attach the CNVB1828 frame to the LR28 front couplers (2) and bottom connection pin (7). Make the angle adjustments on the LR18 modules. Lower the LR28 array onto the top LR18 module on the Pre rig. You can, of course, also mount individual LR18 modules to the LR24 array. Mount the LR18 front couplers to the inside points of the CNVB1828 and pin them. Take out the LR18 angle arm and mount it to the rear mounting point of the CNVB1828 and pin with the pin through the hole of the angle arm. Raise the LR28 array and make the necessary cable connections.

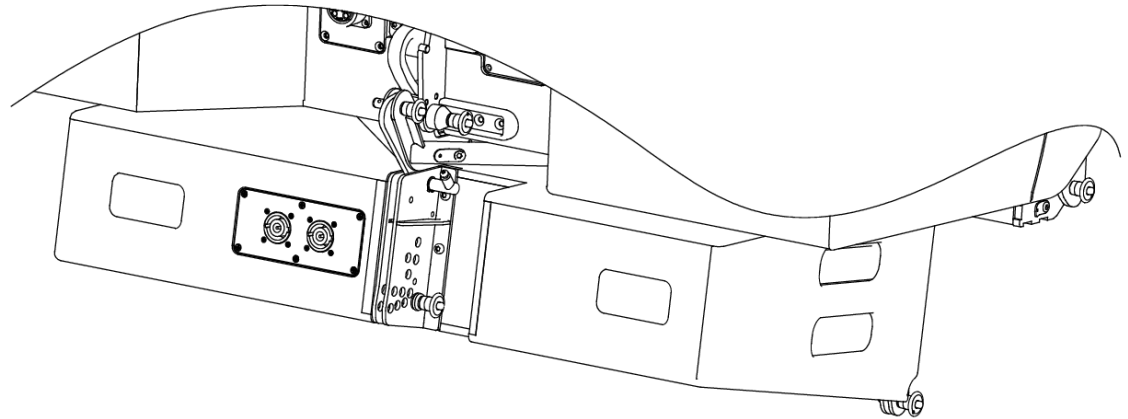

6. Service and support

Warranty

Summary

Alcons Audio BV warrants the original purchaser and any subsequent owner of each new Alcons product, for a period of six years limited from the date of the original purchase by the original purchaser that the new Alcons product is free of defects in materials and workmanship. Alcons Audio BV warrants the new Alcons product regardless of the reason for failure, except as excluded in this warranty. In order to obtain warranty, you must keep the original sales receipt to establish the exact date of purchase.

Items excluded from warranty

Warranty does not cover any product which has been damaged because of any misuse, accident, or negligence. Warranty also does not extend to a new Alcons product if the serial number has been defaced, altered or removed.

What we will do

Alcons Audio BV will replace defective parts and repair malfunctioning products, regardless of the reason for failure (except as excluded). Warranty work can only be performed at our authorized service centres, or at our factory.

Disclaimer

Alcons Audio BV is not liable for any damage to loudspeakers, amplifiers, or any other equipment that is caused by negligence, misuse or improper installation. Alcons Audio BV is not liable for any incidental damages resulting from any defect in the new Alcons product. This includes any damage to another product or products resulting from such a defect.

Alcons Audio BV reserves the right to change specifications without notice.

6. Service and support

Contact information

Mailing address:

Alcons Audio BV
De Corantijn 10
1689 AP ZWAAG
The Netherlands

Telephone

+31 (0)229 283090

World Wide Web:

<http://www.alconsaudio.com>

E-mail:

info@alconsaudio.com



7. EC declaration of conformity

Alcons Audio BV
De Corantijn 10
1689 AP ZWAAG
The Netherlands

States that the following products:
LR28(B) Rigging System

are in conformity with the provisions of the following EC directives and applicable amendments:

Machinery 2006/42/EC

and the national laws to enforce this directive,

National standards and technical specifications applied: *DIN EN ISO 12 100, DIN EN 1050, BGV C1*

provided the mounting components are unaltered/modified and in “factory-original” condition.

Established at Zwaag, the Netherlands,
December 1, 2022

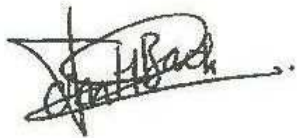

T.H. Back
Managing Director



Notes

