



LR18i

compact installation line-array module

user's manual

Featured models:
LR18i



evolutionary audio solutions™

Table of contents

| | | |
|---|---|----|
| 1 | Introduction | 3 |
| 2 | Important safety instructions and precautions | 4 |
| 3 | Installation | 5 |
| 4 | Rigging components | 6 |
| 5 | Array configurations | 9 |
| 6 | Service and support | 16 |
| 7 | CE declaration of conformity | 17 |



1. Introduction

Dear customer,

Congratulations on your purchase of an Alcons Audio LR18i line array loudspeaker and thank you for your confidence in Alcons products. We are very honoured to welcome you to the growing family of Alcons ambassadors!

For your safety, please read the important safety instructions and the precautions section before rigging a loudspeaker array.

General features

The LR18i has the following features:

A unique seamless arrayability up to/beyond 20kHz.

Symmetrical 90° or 120° dispersion in the non-coupling plane.

High-performance line-array system for even demanding applications.

Non-compressed 1:1 HiFi-quality sound reproduction.

Intuitive predictable linear response behavior and identical tonal balance at any SPL.

7" pro-ribbon HF section with exceptional intelligibility and "throw".

Maximum dynamic headroom reserve with up to 90% less distortion.

Fully coherent and symmetric pattern control in horizontal and vertical plane.

SIS™ pre-wired for very high system damping and further reduced distortion.

All Neodymium drivers for excellent performance-to-weight ratio.

LR18i rigging features

The trapezoidal cabinet is fitted with integrated mounting hardware, enabling angle-setting on the cabinets during installation. The rigging system is intended for fixed installation use and has a max. working load limit of 24x LR18i cabinets under 10:1 safety (with GRD18(B)).

Manual

This manual is written in a compact and easy readable way. You can contact Alcons Audio for more in-depth information on different items or situations



2. Important safety instructions and precautions

Read this manual

1. Follow all safety instructions as well as the warning messages.
2. Never incorporate equipment or accessories not approved by Alcons Audio.
3. Read all the related product information before using the system.
4. Work with qualified personnel for rigging the system.
5. Installation should only be carried out by qualified personnel who are familiar with the rigging techniques and safety recommendations stated in this manual.
6. Ensure health and safety during installation and setup.
7. All persons must wear protective headgear and footwear at all times. Under no circumstances personnel is allowed to climb into a loudspeaker assembly.
8. Respect the Working Load Limit (WLL) of third party equipment.
9. Alcons Audio is not responsible for any rigging equipment and accessories provided by third party manufacturers. Verify that the Working Load Limit (WLL) of the suspension points, chain hoists and all additional hardware rigging accessories is respected.
10. Respect the maximum configurations and the recommended safety level.
11. For safety issue, respect the maximum configurations outlined in this manual. To check the conformity of any configuration in regards with the safety level recommended by Alcons Audio.
12. Be cautious when flying a loudspeaker array. Always verify that no one is standing underneath the loudspeaker array when it is being raised or lowered. As the array is being raised, check each individual element to make sure that it is securely fastened to the adjacent element.
13. Never leave the array unattended during the installation process. As a general rule Alcons Audio recommends the use of safety slings at all times.
14. Ensure that the surface is suitable for ground-stacking a loudspeaker array.
15. Do not stack the loudspeaker array on unstable ground or surface. If the array is stacked on a structure, platform, or stage, always check that the latter can support the total weight of the array. As a general rule, Alcons Audio recommends the use of safety straps at all times.



The exclamation point within a triangle is intended to alert the user to the presence of important operating instructions in the literature accompanying the product.

3. Installation

Unpacking

Carefully open the shipping carton and inspect all the parts. Every Alcons product is thoroughly tested and inspected before leaving the factory and should arrive in perfect condition. If you find any damage, notify the shipping company immediately. Only you, the consignee, may initiate a claim for shipping damage. Be sure to save all packing materials for the carrier's inspection.



4. Rigging components

LR18 loudspeaker

- | | |
|-----------------------|--|
| 1) LR18i cabinet | LR18i cabinet |
| 2) Front coupler | front couplers with nut and bolt connection |
| 3) Signal input/ link | Input/ link for the audio signal |
| 4) Angle frame | frame supports features for the angle setting and coupling |
| 5) Angle bar | bar with holes for angle setting and coupling |

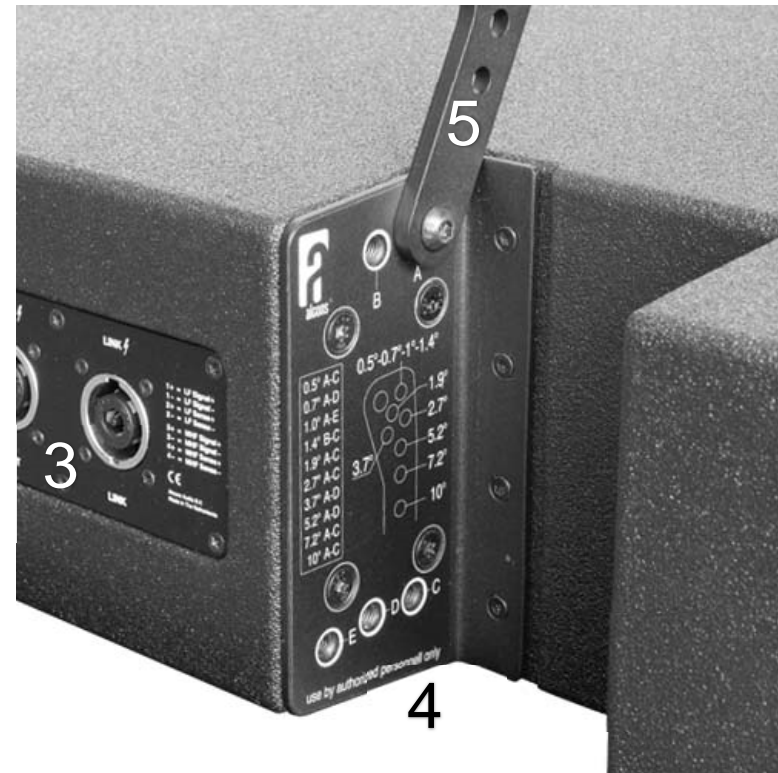
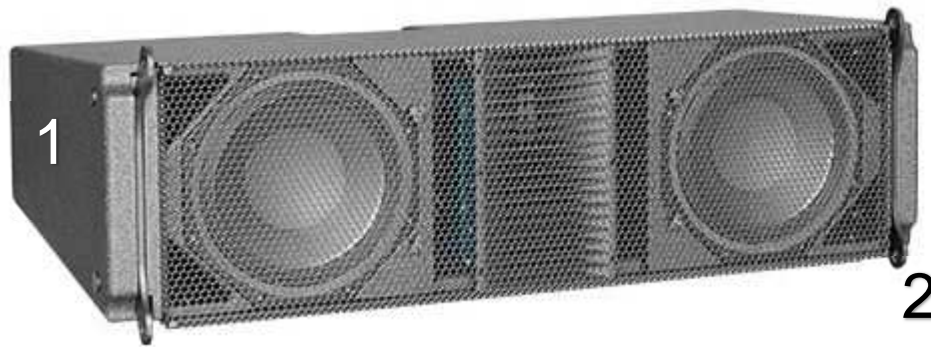

4. Rigging components



GRD18i

The GRD18i enables the LR18i line-array modules to be flown and ground stacked. The grid can be suspended from multiple hoist positions on top of the grid or by means of a central “single pick-point” for smaller arrays; all points 11mm/0.44-in for 0,75T shackles.

The GRD18i is certified for a safety-rating of 10:1, for twelve (12) cabinets LR18i

GRD18

The GRD18 enables the LR18i line-array modules to be flown and ground stacked. The grid can be suspended from multiple hoist positions on top of the grid or by means of a central “single pick-point” for smaller arrays; all points 14mm/0.55-in for 1,5T shackles. It has a mounting position and through hole for the Teqsas laser/inclinometer.

The GRD18 is certified for a safety-rating of 10:1, for twenty-four (24) cabinets LR18i.



4. Rigging components

GRD18B

The GRD18B enables the LR18i line-array modules and LR18B line-array bass modules to be flown and ground stacked. The grid can be suspended from multiple hoist options on top of the grid or with the central “single pick-point” bar for smaller arrays (all points 14mm/0.55-in for 1,5T shackles). The GRD18B has a weight of 26 kg / 57 lb and is certified for a safety-rating of 10:1, for 24 cabinets LR18i, 12 cabinets LR18B * on the hoist positions on top of the grid.

* (or equivalent weight in mixed configurations)

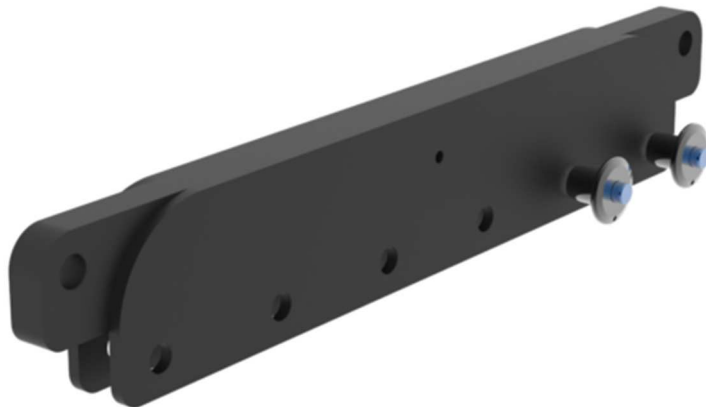

GRD18EXTBR

This is a “sliding” extension bar, which can be attached on top of the GRD18, to extend the leverage capabilities of the GRD18, with larger centre-of-gravity (COG) array off-sets. With the GRD18EXTBR mounted at the front side of the GRD18, the upward array tilt is extended; With the GRD18EXTBR mounted at the rear side of the GRD18, the downward array tilt is extended. The front and rear holes measure 14mm/0.55-in to facilitate 1,5T shackles. Always use both quick release pins for the GRD18/ GRD18EXTBR connection.

5. Array configurations

Cabinet connections LR18i

There are 10 user selectable logarithmic angles, which can be determined by the Alcons Ribbon Calculator™ simulation program. The angle lay-out is pictured on the right. To set a desired angle, two holes in the angle bar need to be positioned between the marked holes A,B on one cabinet and C,D and E on the adjacent cabinet.

The picture below shows the front coupling with locating bolts.

It is important to mention that the angle setting on the desired cabinet is done at the previous cabinet.

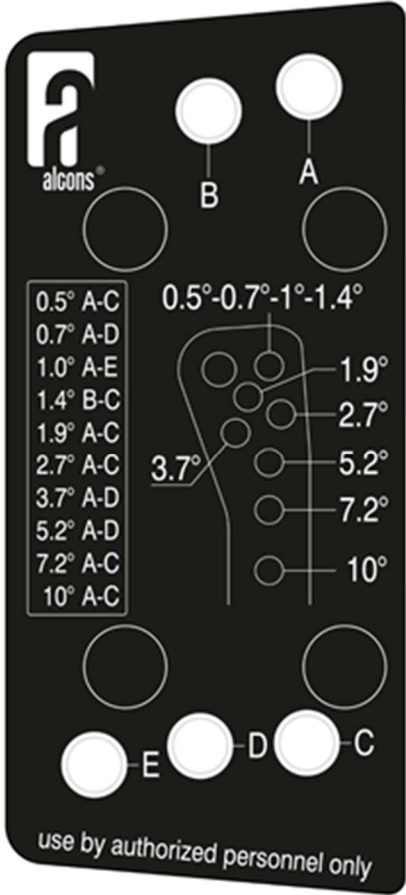
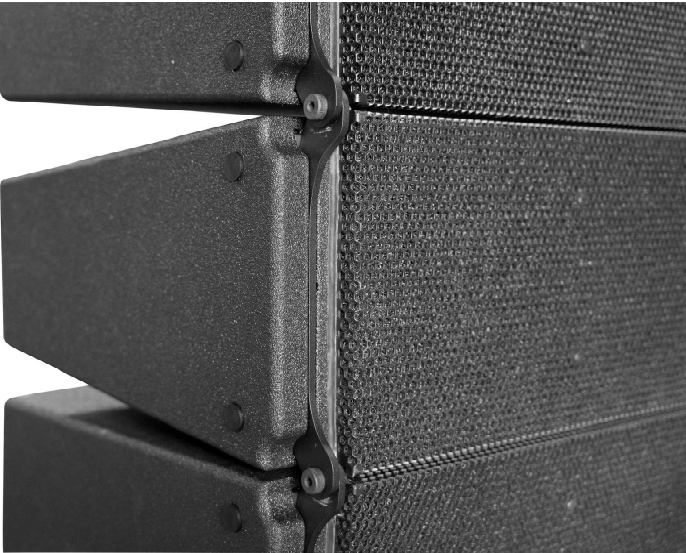

5. Array configurations

GRD18i options

The GRD18i is used with 1-12 LR18i arrays and has multiple mounting options. The picture on the right shows the different pick-points for flying an array. The A1 & A2 marked points are the default hoist points.

It is possible to use one pick point from the A1 linear pattern. Use one pick point only for max. 6x LR18i cabinets

When hanging a 6-12 LR18i array with 2 hoist points, ensure that the Centre of Gravity is evenly spaced between the two A1 pick points.

In case of a permanent installation, combine an A1 point and 2x A2 for a stable 3-point hang. **Use 0,75T shackles at all times** Hole A4 can be used for a cable sling attachment, or an extra safety steel to the bottom cabinet of the array.

The 2 holes A5 will hold the connection bolt between the LR18i angle arm and GRD18i.

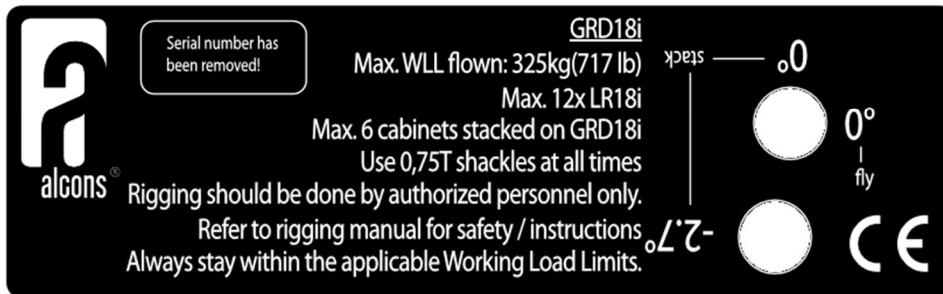
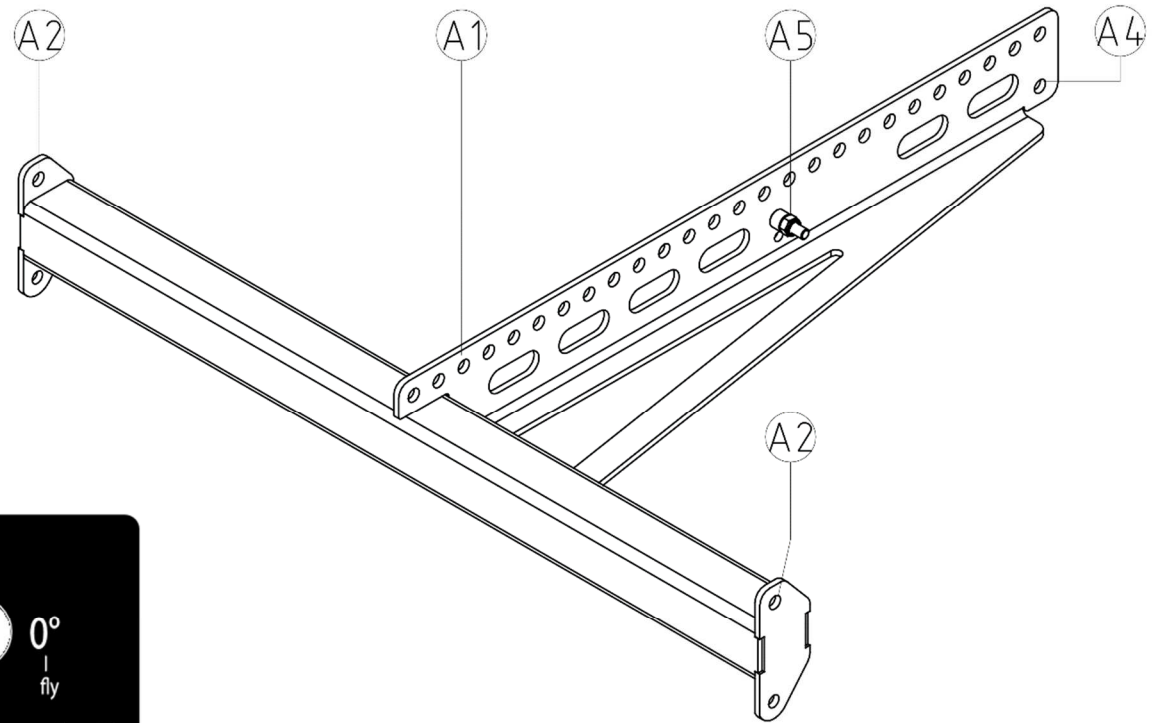

Picture of the GRD18i sticker situated at the A5 marked area. The -2.7° hole is only used when stacking an LR18i array.

5. Array configurations

GRD18 options

The GRD18 is used with 12-24 LR18i arrays and has multiple mounting options. The picture on the right shows the different pick-points for flying an array. The A1 & A2 marked points are the default hoist points.

It is possible to use one pick point from the A1 linear pattern. Use it only for max. 12x LR18i cabinets

When hanging a 6-12 LR18i array with 2 hoist points, ensure that the Centre of Gravity is evenly spaced between the two A1 pick points.

In case of a permanent installation, combine points A1 and 2x A2 for a stable 3-point hang. **Use 1,5T shackles at all times**

A3 indicates the mounting position of an angle inclinometer. It has a 4x $\varnothing 4\text{mm}$; 16.5mm x 108.8mm hole pattern for the Teqsas laser/inclinometer.

Hole A4 can be used for a cable sling attachment.

The 2 holes A5 will hold the connection pin between the LR18i angle arm and GRD18

The picture below shows the orientation of the LR18i angle bar inside the GRD18 and GRD18B. The angles are also indicated on the GRD sticker.

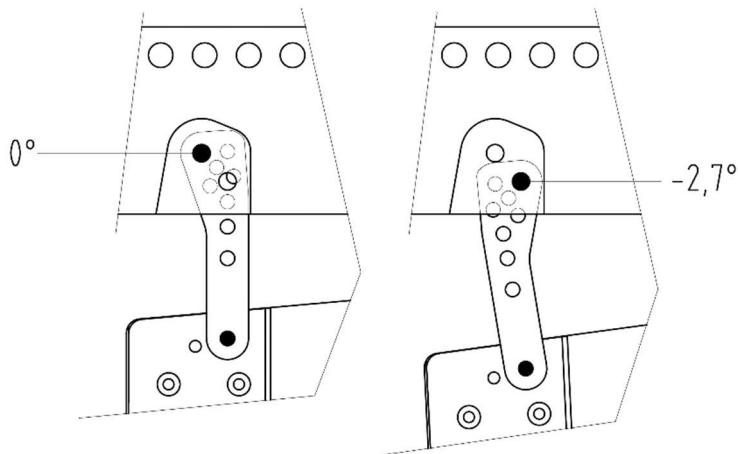
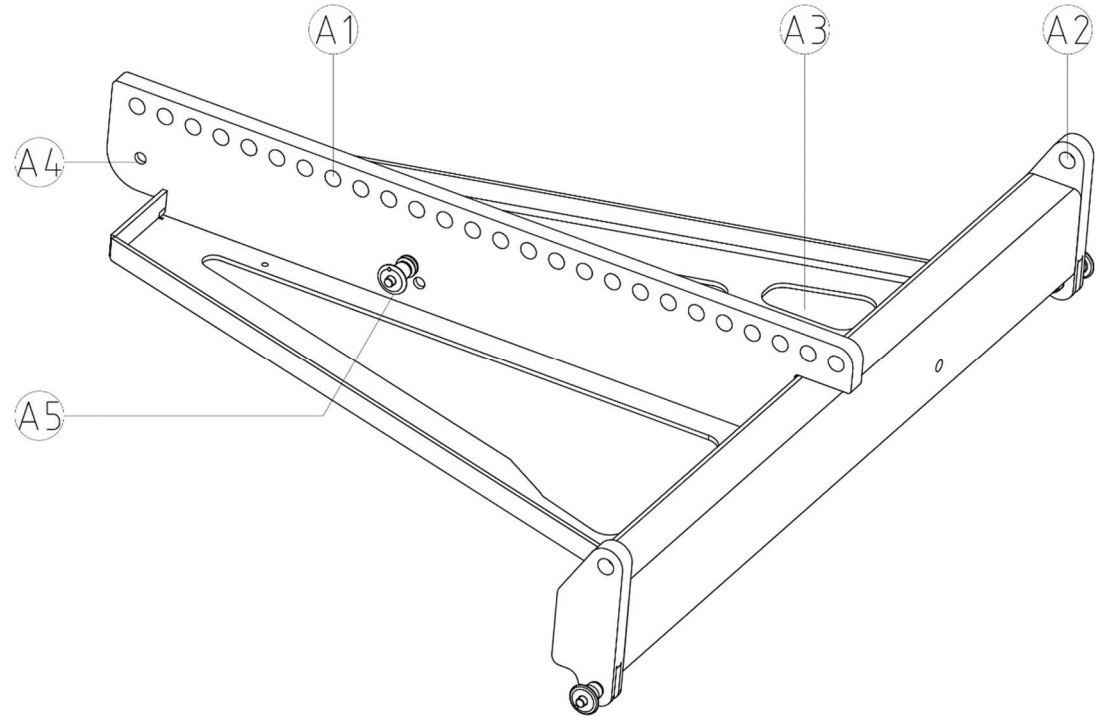

5. Array configurations

GRD18B options

The GRD18B has multiple mounting options. The picture on the right shows the different pick-points for flying an array. The A1 & A2 marked points are the default hoist points.

It is also possible to use one pick point from the A1 linear pattern. Use it only for max. 12x LR18i or 6 LR18B cabinets

When hanging a 12-24 LR18i or 8-12 LR18B array with 2 hoist points, use the **outermost** front and rear A1 pick points.

Preferably, combine points A1 and A2 for a stable 3 or 4-point hang. **Use 1,5T shackles at all times**

A3 indicates the mounting position of an angle inclinometer. It has a 4x $\varnothing 4\text{mm}$; 16.5mm x 108.8mm hole pattern for the Teqsas laser/ inclinometer.

The 2 holes A5 will hold the connection pin between the LR18i angle arm and GRD18B

A8 marks the angle arm which can connect to the bottom connection points on the LR18B. Turn the arms horizontally into their recesses and lock with the G1 pins, when using GRD18B as a top grid.

G2 connects to the front coupling of a LR18i, using the bottom hole.

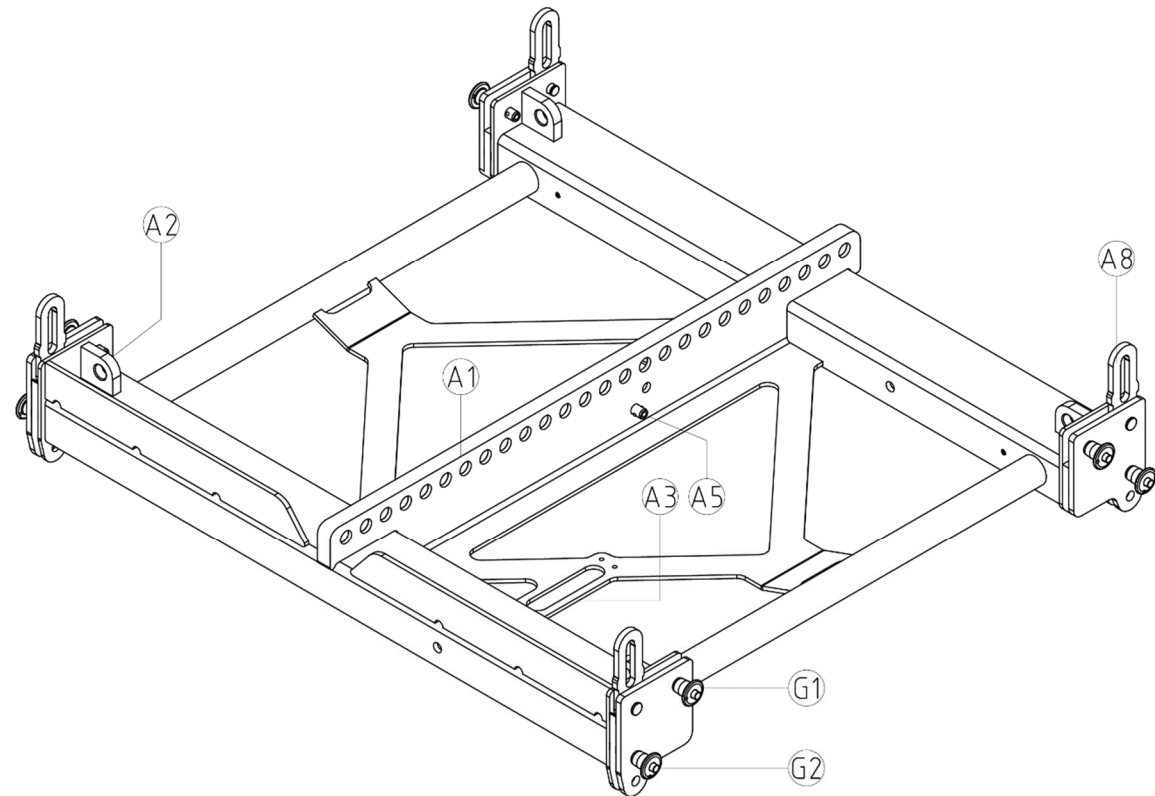

5. Array configurations

LR18i array assembling

Required tools: Allan key wrench 5mm, thin 13mm wrench, long 13mm combination wrench and torque wrench 5-20Nm.

Start by mounting GRD18i(1) onto the top LR18i cabinet. Use the supplied locating bolts and black locking nuts for the front couplers(2). Align the A/B hole with the "A" hole in the angle frame(5) with the collar bolt(6) and the 0,5°/hole GRD18i to the 0° hole of the GRD18i. Pin the long M8 bolt and slide the black bushing onto the bolt end. Lock the connection with the black locking nut.

Hoist the GRD18i and cabinet and tighten the bolt connections firmly. Make the first inter-cabinet connection. Align the front coupler holes and pin with the locating bolt and locking nuts. Due to the tight space, a thin wrench is preferred. A "long nose plier" can also be used, to align and screw the nut onto the locating bolt ->15Nm.

Make the correct angle connection. These are stated on the angle frame. Apply thread locking fluid on the collar bolts(6) for the angle connection. Raise the array and tighten up the bolt connections->15Nm. Repeat these steps for the remaining cabinets.

When the assembled array has been raised, check all bolt connections.

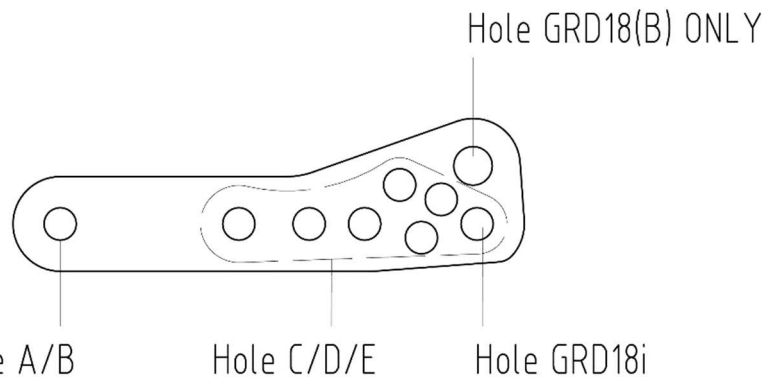
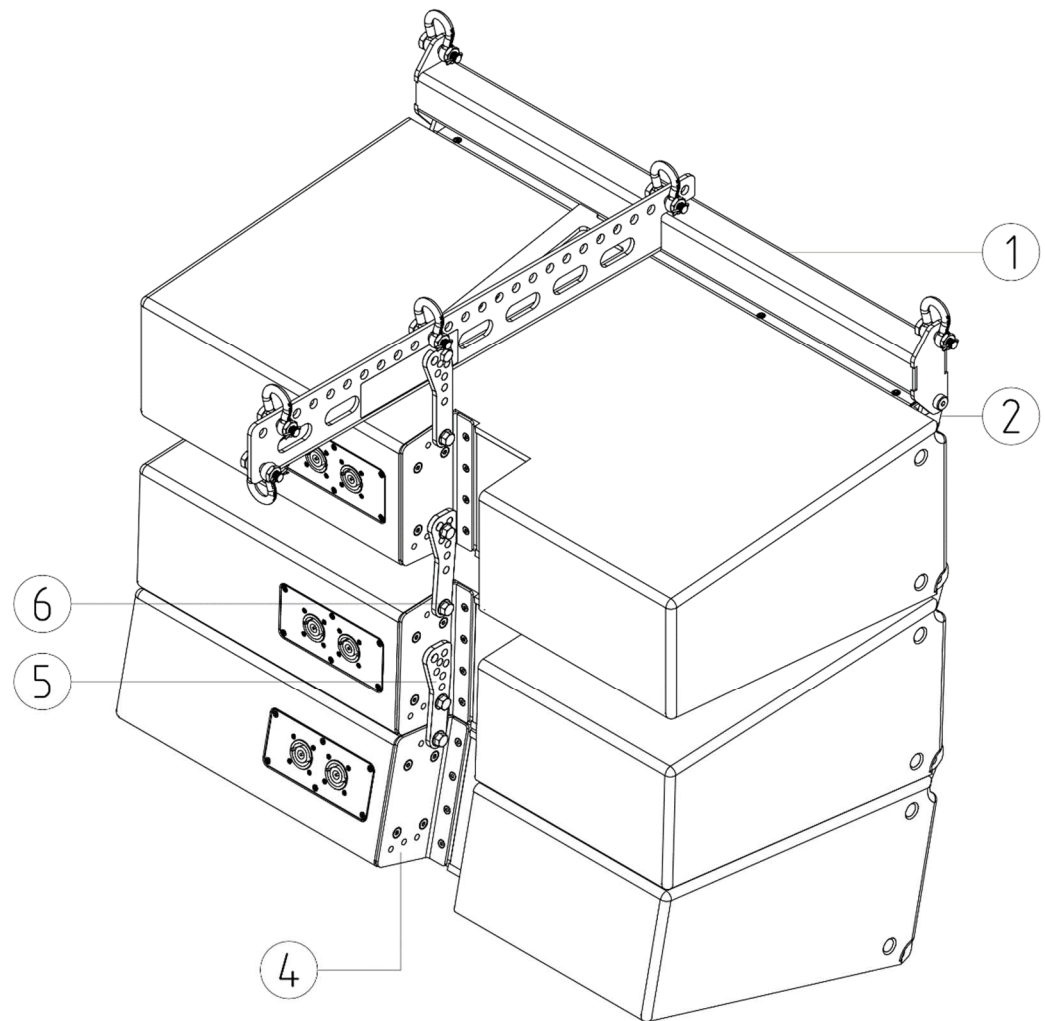

5. Array configurations

LR18i ground stacking

The maximum allowed number of cabinets in ground stacked mode with GRD18i is six.



Make sure that the array is assembled on a flat and stable surface

Required tools: Allan key wrench 5mm, thin 13mm wrench, long 13mm combination wrench and torque wrench 5-20Nm.

Place the GRD18i(1) on a flat and stable surface. Begin with the first cabinet. Use the supplied locating bolts and black locking nuts for the front couplers(2). Align the A/B hole with the “A” hole in the angle frame(5) with the collar bolt(6) and the 0,5°/hole GRD18i to the 0° or -2,7° on GRD18i. Pin the long M8 bolt and slide the black bushing onto the bolt end. Lock the connection with the black locking nut. Make the first inter-cabinet connection. Align the front coupler holes and pin with the locating bolt and locking nuts. Due to the tight space, a thin wrench is preferred. A “long nose plier” can also be used, to align and screw the nut onto the locating bolt->**15Nm**.

Make the correct angle connection. These are stated on the angle frame. use the collar bolts(6) for the angle connection. Tighten up the bolt connections->**>15Nm** . Repeat these steps for the remaining cabinets.
When the assembled array has been raised, check all bolt connections.

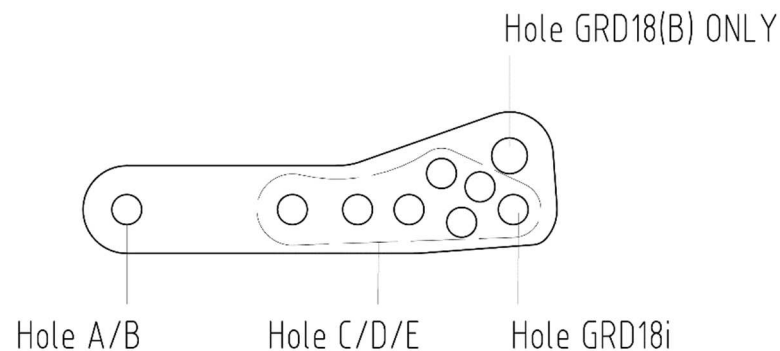

6. Service and support

Warranty

Summary

Alcons Audio BV warrants the original purchaser and any subsequent owner of each new Alcons product, for a period of six years limited from the date of the original purchase by the original purchaser that the new Alcons product is free of defects in materials and workmanship. Alcons Audio BV warrants the new Alcons product regardless of the reason for failure, except as excluded in this warranty. In order to obtain warranty, you must keep the original sales receipt to establish the exact date of purchase.

Items excluded from warranty

Warranty does not cover any product which has been damaged because of any misuse, accident, or negligence. Warranty also does not extend to a new Alcons product if the serial number has been defaced, altered or removed.

What we will do

Alcons Audio BV will replace defective parts and repair malfunctioning products, regardless of the reason for failure (except as excluded). Warranty work can only be performed at our authorized service centres, or at our factory.

Disclaimer

Alcons Audio BV is not liable for any damage to loudspeakers, amplifiers, or any other equipment that is caused by negligence, misuse or improper installation. Alcons Audio BV is not liable for any incidental damages resulting from any defect in the new Alcons product. This includes any damage to another product or products resulting from such a defect.

Alcons Audio BV reserves the right to change specifications without notice.

6. Service and support

Contact information

Mailing address:

Alcons Audio BV
De Corantijn 10
1689 AP ZWAAG
The Netherlands

Telephone:

+31 (0)229 283090

World Wide Web:

<http://www.alconsaudio.com>

E-mail:

info@alconsaudio.com



7. EC declaration of conformity

Alcons Audio BV
De Corantijn 10
1689 AP ZWAAG
The Netherlands

States that the following products:
LR18i Rigging System

are in conformity with the provisions of the following EC directives and applicable amendments:

Machinery 2006/42/EC

and the national laws to enforce this directive,

National standards and technical specifications applied: *DIN EN ISO 12 100, DIN EN 1050, BGV C1*

provided the mounting components are unaltered/modified and in “factory-original” condition.

Established at Zwaag, the Netherlands,
December 1, 2022



T.H. Back
Managing Director



Notes

