



LR7

micro line-array

user's manual



evolutionary audio solutions™

Table of contents

1	Introduction	3
2	Important safety instructions and precautions	4
3	Installation	5
4	Rigging components	6
5	Array configurations	8
6	Service and support	20
7	CE declaration of conformity	22



1. Introduction

Dear customer,

Congratulations on your purchase of an Alcons Audio LR7 line array loudspeaker and thank you for your confidence in Alcons products. We are very honoured to welcome you to the growing family of Alcons ambassadors!

For your safety, please read the Important safety instructions and the precautions section before rigging a loudspeaker array.

General features

The LR7 has the following features:

High-performance, easy handling, micro line-array system for demanding applications.

4" pro-ribbon HF section with exceptional intelligibility and "throw".

Intuitive predictable linear response behavior and identical tonal balance at any SPL.

Non-compressed 1:1 HiFi-quality sound reproduction.

Maximum dynamic headroom reserve with up to 90% less distortion.

A unique seamless arrayability up to/beyond 20kHz.

Fully coherent pattern control in horizontal and vertical plane.

SIS™ pre-wired for very high system damping and further reduced distortion.

All Neodymium drivers for excellent performance-to-weight ratio.

Available with 120° or 90° dispersion in the non-coupling plane.

LR7 rigging features

The trapezoidal cabinet is fitted with integrated mounting hardware, enabling angle-setting on the cabinets, without lifting the array, resulting in safer and faster set-up with minimal handling. The rigging system features an androgyn array coupling system, which makes it possible to make a symmetrical system by turning the cabinet over. The rigging system has a working load limit of 18x LR7 or 8x LR7B cabinets under 10:1 safety.

Manual

This manual is written in a compact and easy readable way. You can contact Alcons Audio for more in-depth information on different items or situations



2. Important safety instructions and precautions

Read this manual

1. Follow all safety instructions as well as the warning messages.
2. Never incorporate equipment or accessories not approved by Alcons Audio.
3. Read all the related product information before using the system.
4. Work with qualified personnel for rigging the system.
5. Installation should only be carried out by qualified personnel who are familiar with the rigging techniques and safety recommendations stated in this manual.
6. Ensure health and safety during installation and setup.
7. All persons must wear protective headgear and footwear at all times. Under no circumstances personnel is allowed to climb into a loudspeaker assembly.
8. Respect the Working Load Limit (WLL) of third party equipment.
9. Alcons Audio is not responsible for any rigging equipment and accessories provided by third party manufacturers. Verify that the Working Load Limit (WLL) of the suspension points, chain hoists and all additional hardware rigging accessories is respected.
10. Respect the maximum configurations and the recommended safety level.
11. For safety issue, respect the maximum configurations outlined in this manual. To check the conformity of any configuration in regards with the safety level recommended by Alcons Audio.
12. Be cautious when flying a loudspeaker array. Always verify that no one is standing underneath the loudspeaker array when it is being raised or lowered. As the array is being raised, check each individual element to make sure that it is securely fastened to the adjacent element.
13. Never leave the array unattended during the installation process. As a general rule Alcons Audio recommends the use of safety slings at all times.
14. Be cautious when ground-stacking a loudspeaker array.
15. Do not stack the loudspeaker array on unstable ground or surface. If the array is stacked on a structure, platform, or stage, always check that the latter can support the total weight of the array. As a general rule, Alcons Audio recommends the use of safety straps at all times.
16. Take into account the wind effects on dynamic load.
17. When a loudspeaker assembly is deployed in an open air environment, wind can produce dynamic stress to the rigging components and suspension points. If the wind force exceeds 6 Beaufort scale, lower down and/or secure the loudspeaker array.



The exclamation point within a triangle is intended to alert the user to the presence of important operating instructions in the literature accompanying the product.

3. Installation

Unpacking

Carefully open the shipping carton and inspect all the parts. Every Alcons product is thoroughly tested and inspected before leaving the factory and should arrive in perfect condition. If you find any damage, notify the shipping company immediately. Only you, the consignee, may initiate a claim for shipping damage. Be sure to save all packing materials for the carrier's inspection.



4. Rigging components

LR7 loudspeaker

- | | |
|-----------------------|--|
| 1) LR7 cabinet | LR7 cabinet (shown) |
| 2) Front coupler | Front couplers, lockable with quick release pin |
| 3) Pin angle setting | Pin determines the angle between the cabinets |
| 4) Angle arm | Angle setting connection arm, spring loaded |
| 5) Signal input/ link | Input/ link for the audio signal |
| 6) Angle frame | Frame holds features for the angle setting and coupling |
| 7) HF indication | HF 120°/ 90° dispersion and "ribbon right/ ribbon left" indication |
| 8) Parking holes | 2 holes each side for parking a front coupler quick release pin |

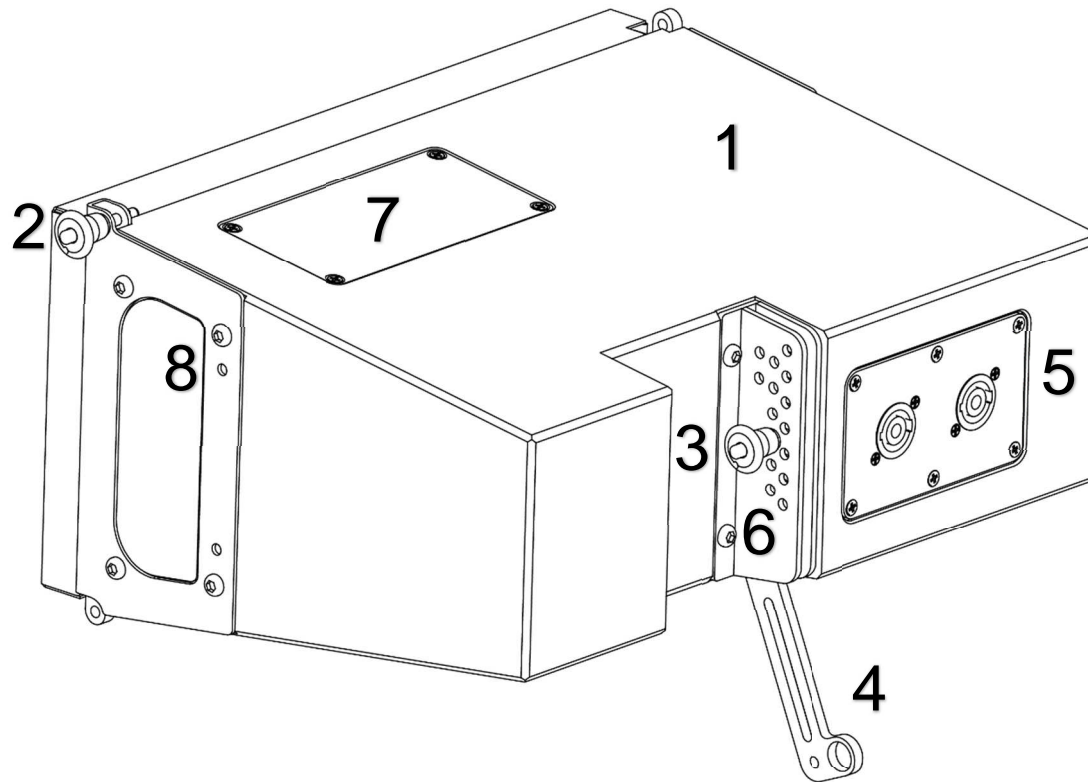

4. Rigging components

LR7B loudspeaker

- | | |
|-----------------------|---|
| 1) LR7B cabinet | LR7B cabinet (shown) |
| 2) Front coupler | Front couplers, lockable with quick release pin |
| 3) LR7B connection | Rear 0° connection to another LR7B |
| 4) LR7 connection | Bottom 0° connection to fly/ stack an LR7 |
| 5) Signal input/ link | Input/ link for the audio signal |
| 6) Bar handles | Handles in the cabinet ensure easy handling |
| 7) Wear strips | Cabinet ground support when stacking |

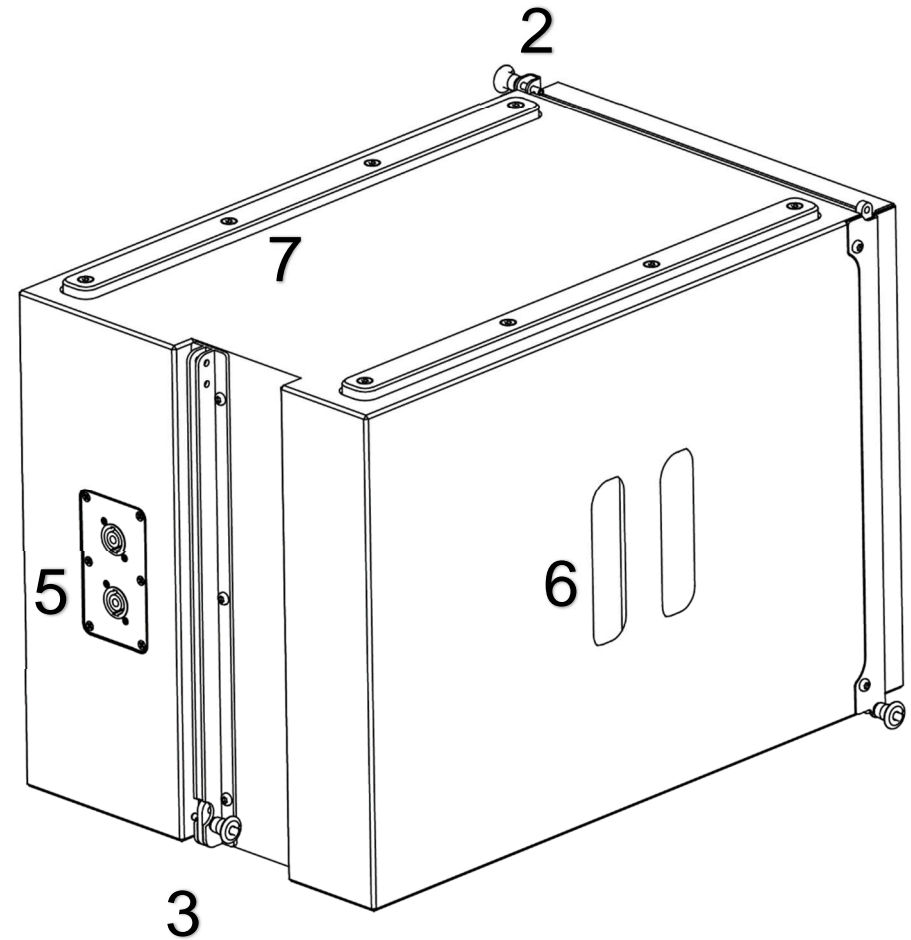
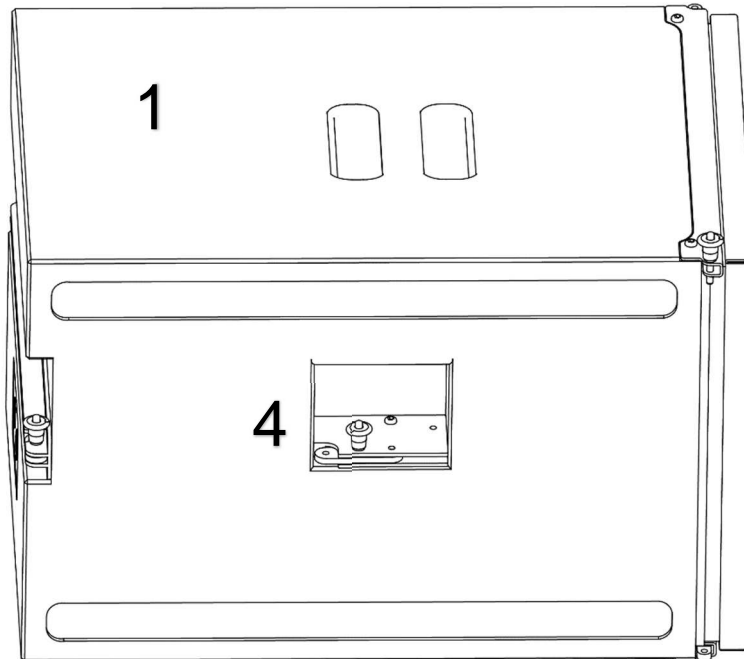

4. Rigging components

GRD7

The GRD7 is the flying and stacking bumper of the LR7 line-array modules. It is also used to fly the LR7B bass extension modules. The grid can be suspended from the central “single pick-point” bar (ø 12mm / 0.5-in. (1T)) and supports the “Androgyn” LR7 flying system. It is fitted with a mounting platform for the Teqsas laser / inclinometer and comes with all quick release pins required (attached to the frame).

The GRD7 is certified for a safety-rating of 10:1, for 18x cabinets LR7 or 8x LR7B cabinets.



BRK3LR7

BRK3LR7 is a swivel yoke for a mini-array of three LR7 line-array modules. The yoke is connected to the middle cabinet with two connecting plates on the side of the cabinet, secured with two quick-release pins each. Up to three LR7 cabinets in stand-configuration and up to four LR7 cabinets in flown configuration can be mounted, while maintaining full line-array functionality. The bracket can be fitted with an optional truss clamp, TV-spigot or STMT stand-mount adapter, with M10 (2) or M12 (1) bolt/nut connection.

The BRK3LR7 is certified for a safety-rating of 10:1, for four (4) cabinets LR7.



4. Rigging components



BRK5LR7

BRK5LR7 is a swivel yoke for a mini-array of five LR7 line-array modules. The yoke is connected to the middle cabinet with two connecting plates on the side of the cabinet, secured with two quick-release pins each. Up to five LR7 cabinets in stand-configuration and up to seven LR7 cabinets in flown configuration can be mounted, while maintaining full line-array functionality.

The bracket can be fitted with an optional truss clamp, TV-spigot or STMT stand-mount adapter, with M10 (2) or M12 (1) bolt/nut connection.

The BRK5LR7 is certified for a safety-rating of 10:1, for seven (7) cabinets LR7.

PNCLMP

The PNCLMP can be used to suspend a LR7 array from a single point. The PNCLMP is attached with the Quick Release pin to a GRD7 pickpoint. The load can be attached to an overhead Truss or bar with a tube diameter of 51mm (2"). It can be horizontally adjusted and fixed. The max. allowed WLL is 250kg.



5. Array configurations

Cabinet connections

The LR7 has 15 user selectable fly and stack angles, which can be determined by the Alcons Ribbon Calculator™ simulation program. The LR7 rigging system has an androgyn set up. This enables a “ribbon right” or “ribbon left” mounting orientation on the GRD7. The graphical indications on the top and bottom of the LR7 cabinet also show the mounted HF wave-guide dispersion type.

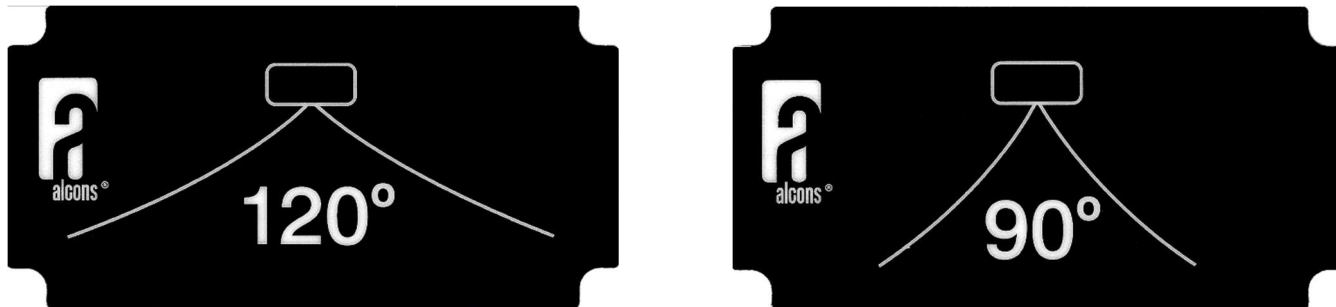

The angle pinning lay-out is pictured below. The angle indication is stated between two holes. The left hole is used when flying an array, the right hole when stacking an array. The fly/ stack configuration is used in both “ribbon right” and ribbon left” mode array orientation. The angle setting arm will point up- or downwards from the cabinet. “Park” indicates the position of the angle pin, when parking the angle arm. This bar is spring loaded and pops out, when the pin is removed from the “park” hole.

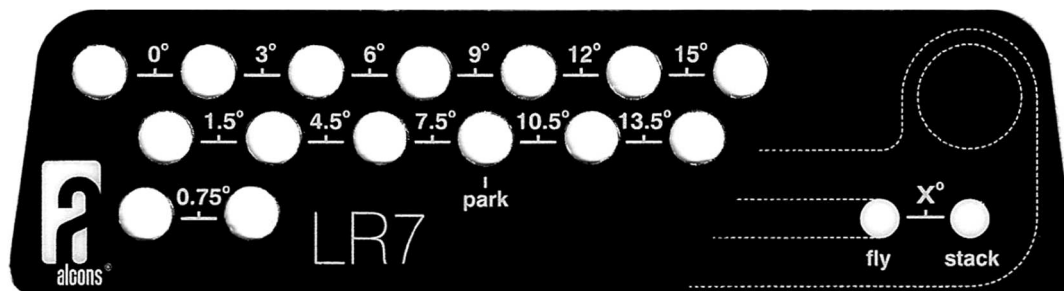

5. Array configurations

GRD7 options

The GRD7 has multiple mounting options. The picture on the right shows the pick-points for flying an array. Use 1 or 2 pick points from the A1 linear pattern. 1 pick point carries 18x LR7 or 6x LR7B cabinets. And LR7 and LR7B combined with a max. weight of 160kg

It is advised to use 2 pick points when assembling tall arrays. Thus the array can be easier aligned and gives a more stable hang.

Use 1T shackles at all times

A2 indicates the mounting position of an angle inclinometer. It has a 4x ø4mm; 16.5mm x 108.8mm hole pattern for the Teqsas laser/ inclinometer.

Hole A4 holds the connection pin to the LR7B cabinet.

A3 marks the connection between GRD7 and LR7.

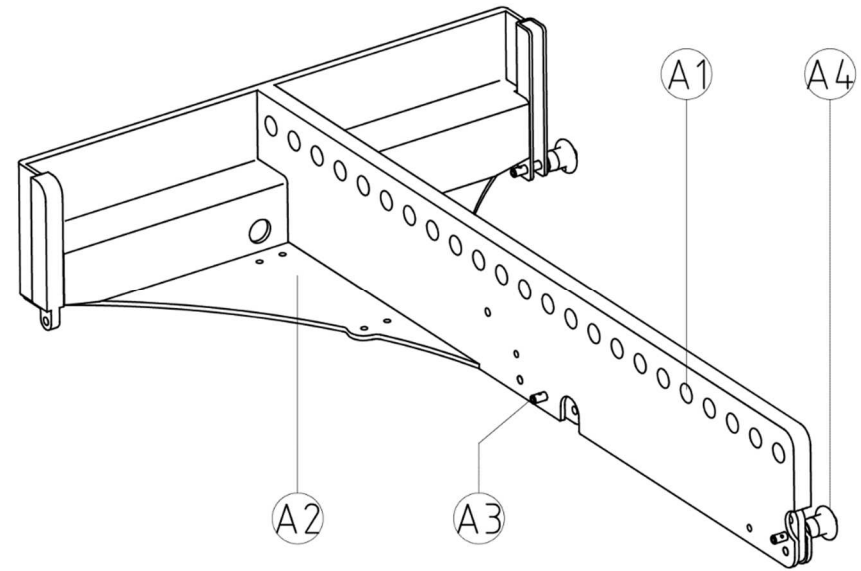

5. Array configurations

GRD7 with LR7 options

The adjacent picture shows the LR7 “androgyn” mounting option with GRD7, to enable LR7 “ribbon right” or “ribbon left” orientation when flying or stacking. The front couplers of the LR7 always fit to the corresponding (front) GRD7 holes.

An extra connecting rod (see arrow) in the middle of the grid is used to connect a “ribbon right” orientated LR7 cabinet to GRD7.

In the “ribbon left” orientation, the angle arm of the LR7 cabinet itself slides into the GRD7 and is secured with the locking pin of the grid.

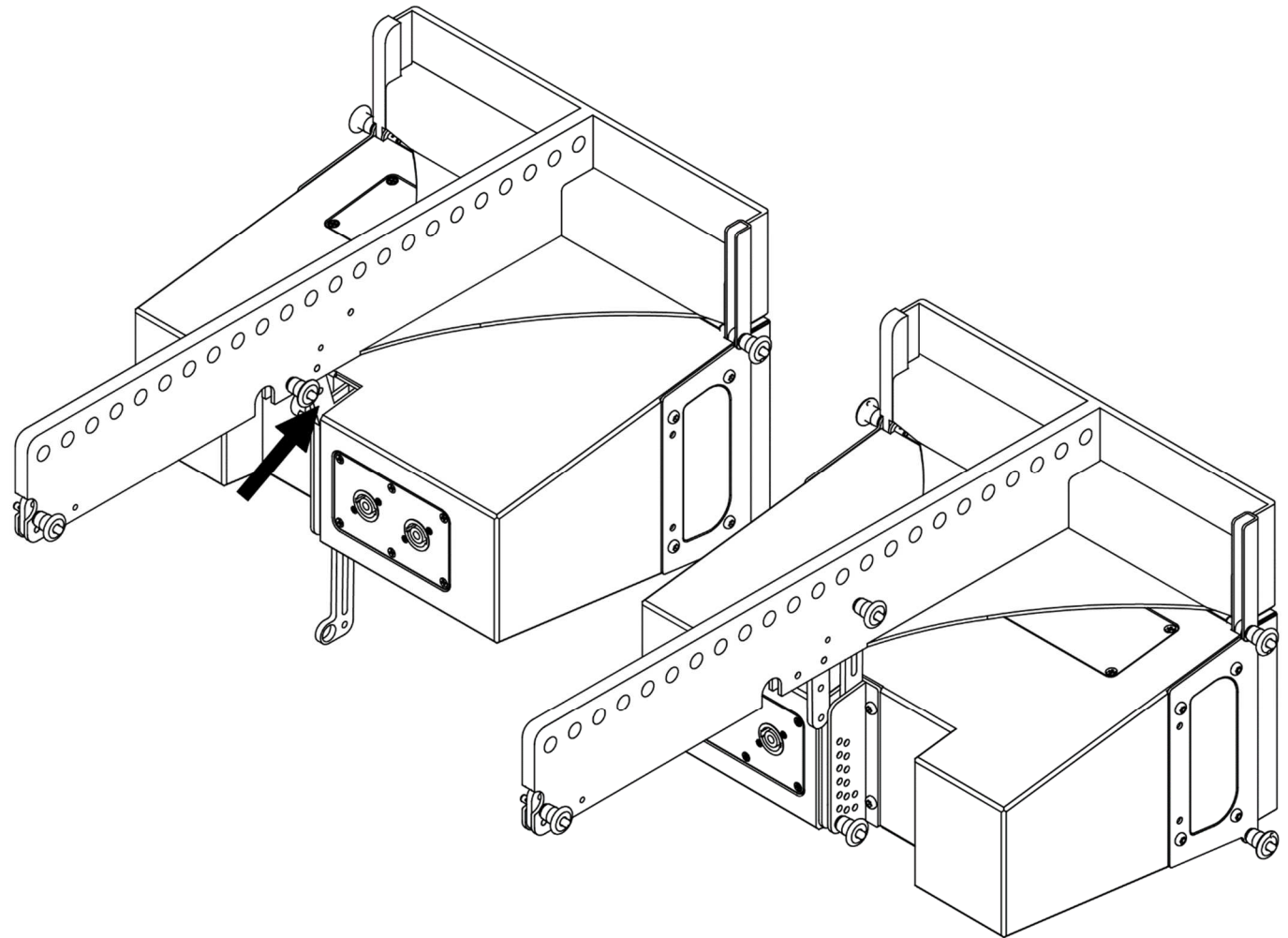

5. Array configurations

GRD7 with LR7B options

This picture shows the connection GRD7 – LR7B using the front and rearmost couplers. LR7B is always top orientated with the wear strips facing GRD7.

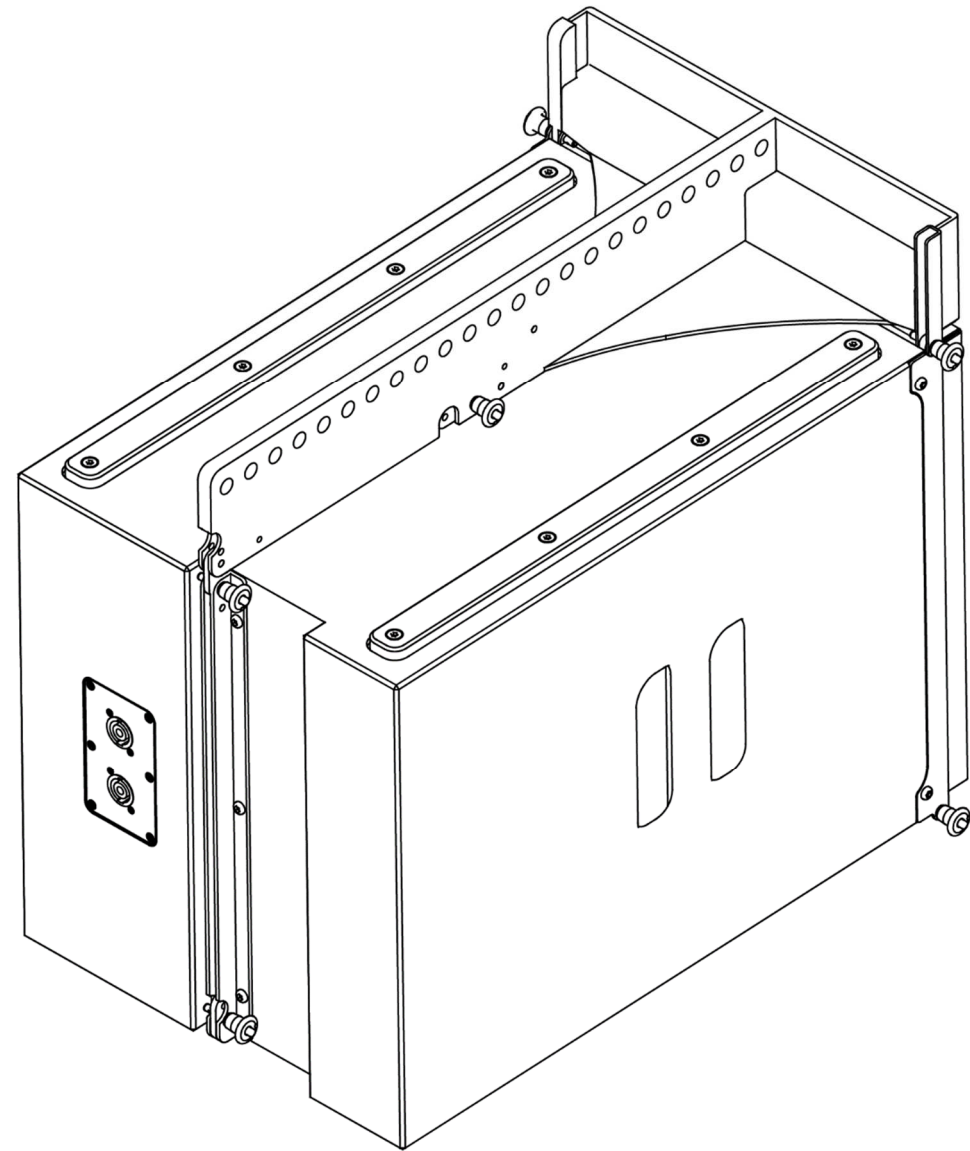

5. Array configurations

LR7 transport and caterpillar array assembling

Array assembling with LR7/ LRB is done using the so-called Caterpillar method. In this case 3 or 6 LR7's are facing downwards on transportable flightcase dollies FC3LR7 or FC6LR7. LR7B can be transported with FC2LR7B and incorporated in the array assembling process. GRD7 can be mounted on both ends of a LR7 array, creating a "ribbon right" or "ribbon left" array. The angle between two cabinets is set on the lower attached cabinet in the "ribbon right" orientation (picture left) and on the upper attached cabinet in the "ribbon left" orientation.

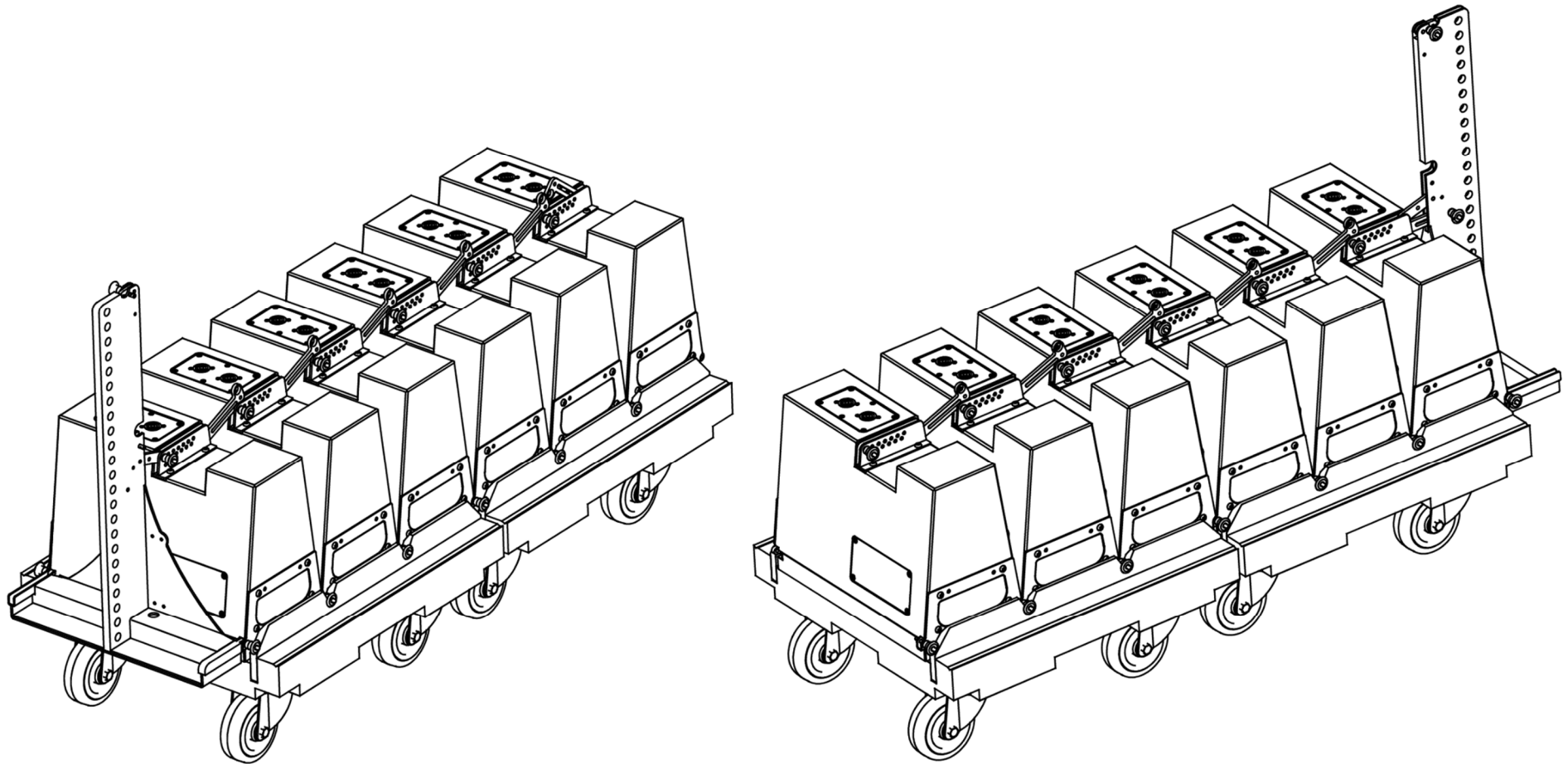

5. Array configurations

Caterpillar style array assembling and hoisting

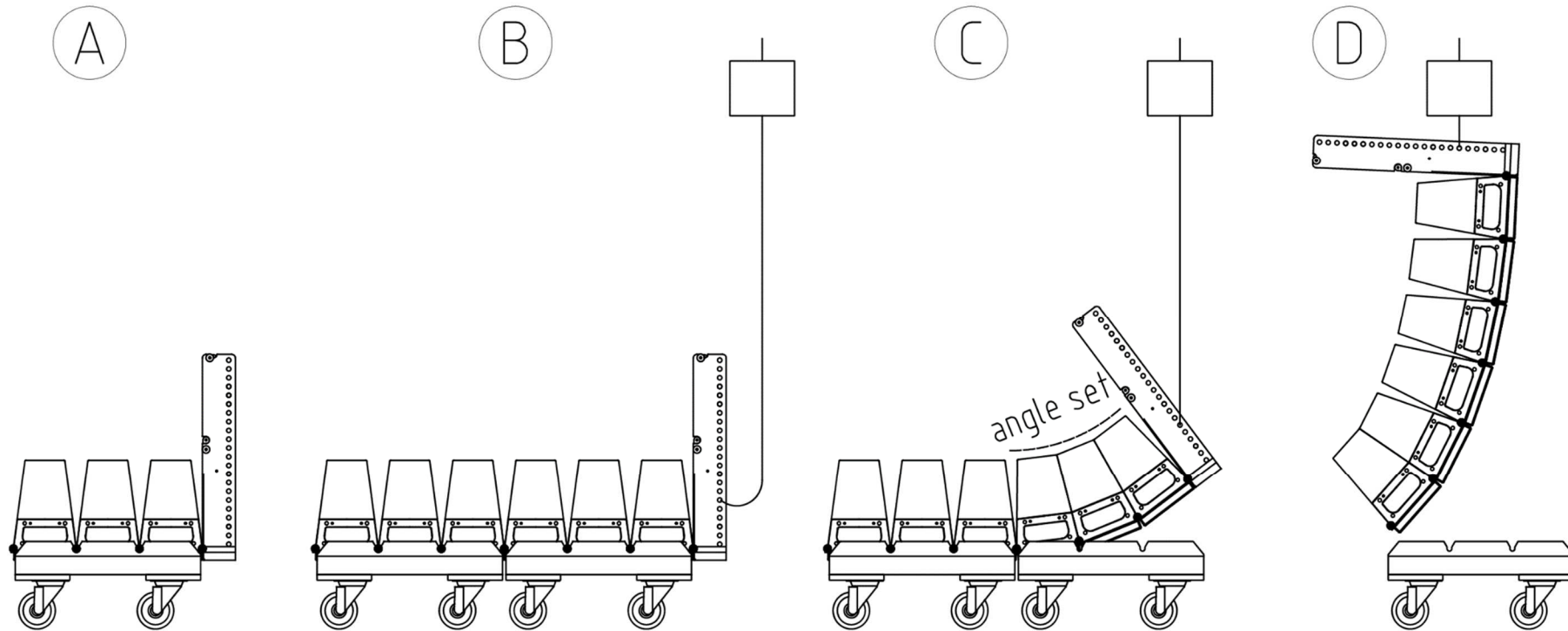

The numbers in the text below, correspond with the LR7 overview pictured earlier.

Shown above depicts array assembling, caterpillar style. Shown with 1 hoist, 1x GRD7 and 6x LR7 cabinets, on 2x FC3LR7 flight case dollies.

Start with attaching the GRD7 to the first cabinet on the FC3LR7 wheel dolly (A). Make sure that the following dolly is lined up correctly for a “ribbon right” or “ribbon left” orientation. Attach the second dolly to the previous one, using the front couplers (B). Attach the hoist to the correct pick-point on the GRD7. Connect the necessary cabling to the signal input/ link (5) connectors. Use a sling from the grid for a tension free cable hang. Start hoisting until the first cabinets compress (C). Take the first dolly away for storage. Pull the angle setting pins (3) out and make the correct angles using the angle arm (4). These angles are determined by the Alcons Ribbon Calculator™ simulation program. Continue doing this until all angles are set. Raise the entire array from the last wheel dolly (D). Be aware that wheel dollies can skate away from the assembling area as the last module detaches.

5. Array configurations



Use slow speed or speed-controllable chain hoists. Avoid any form of excessive dynamic loading to the array assembly

Landing the array caterpillar style

Ensure that the wheel dollies are lined up under the array. Land the bottom pins of the front couplers onto the chamfered edge of the dolly frame. When the bottom cabinets compress, take out the angle setting pins (3). Now this array section can flatten out onto the wheel dollies. Continue doing this with all cabinets. When the complete array is stretched out horizontally, take off all cabling and pull out the front coupling pins between the first and second wheel dolly. Place these pins into the parking hole (8). Then return all angle arms (4) in their parking positions. Now the (in this situation) FC3LR7 cases can be closed up and transported.

5. Array configurations

LR7B connection

LR7B can be added as a bass extension to a LR7 array. This module is flown directly under GRD7. When turned upside down with the wear strips on the ground, a LR7 array can be stacked on top. (max 9pcs)

The connection between 2 LR7B cabinets is done with the front and back couplers. By removing the pin at the rear connection, the small connection bar can be taken out of its recess and aligned with the bracket of the next cabinet. Secure the connection with its locking pin.

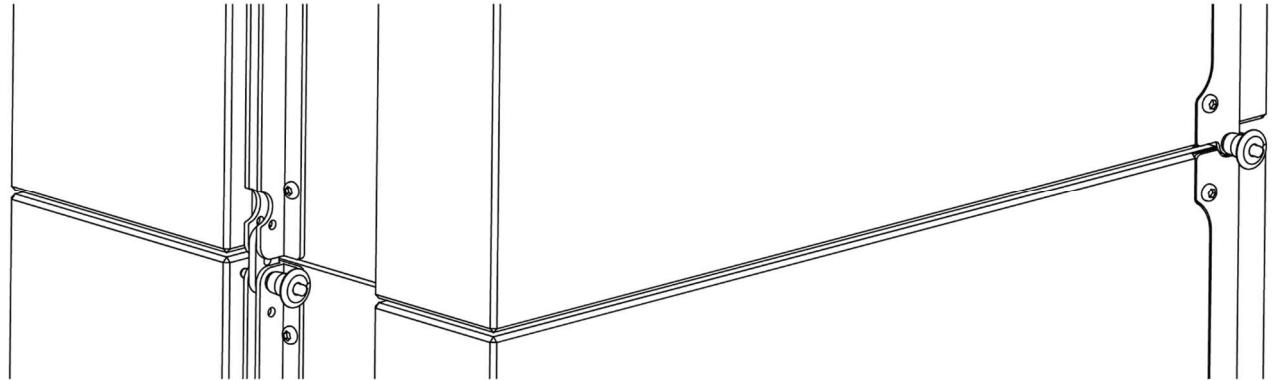

LR7B/ LR7 connection

The LR7 cabinet can be mounted “ribbon right” or “ribbon left” to the LR7B cabinet. The connection bar on the LR7B bracket enables a “ribbon left” LR7 connection; see arrow. The angle arm on the LR7 is used in the “ribbon right” connection. The picture on the right shows a stacked situation. Both connection modes also apply when flying an array.

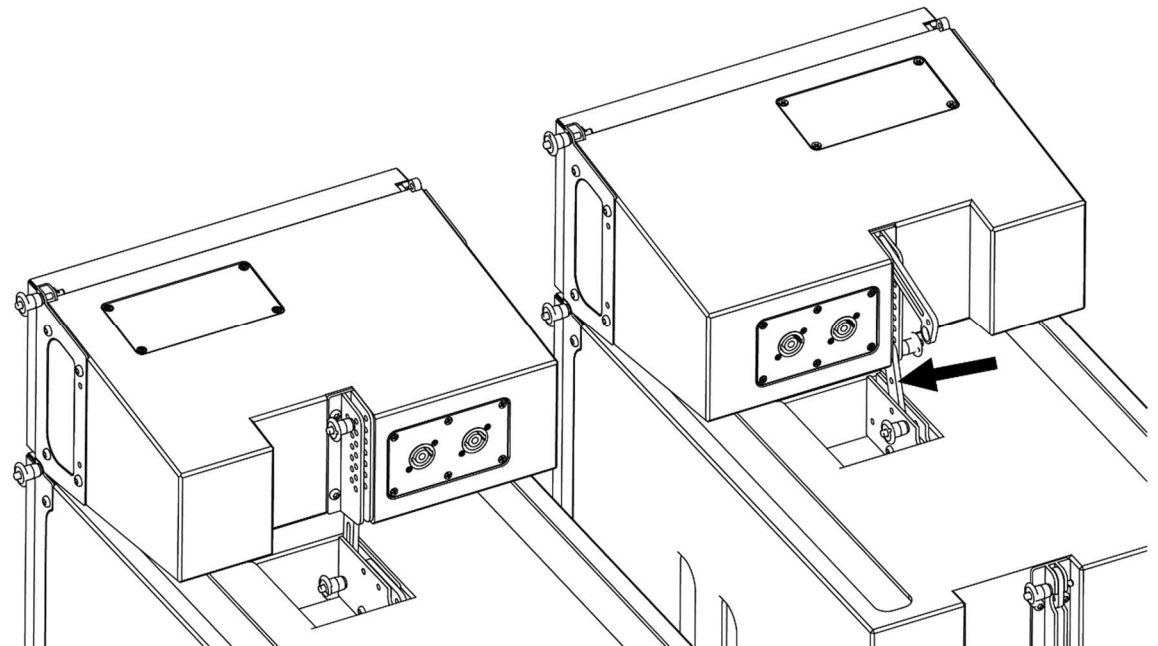

5. Array configurations

Ground stacking

This description features a LR7B as ground support with 3 LR7 “ribbon left” orientated cabinets . The maximum allowed number of cabinets in ground stacked mode is 9pcs mounted to GRD7 or LR7B.



Make sure that the array is assembled on a flat and stable surface

Begin by positioning LR7B in ground stack mode, with the wear strips onto the ground. Ensure that the centre of gravity will be well within the LR7B base. This can be determined by the Alcons Ribbon Calculator™ simulation program. Connect the first cabinet onto LR7B with the front couplers (2). Take out the small bar of the LR7B/ LR7 connection and line it up to the 0° “fly” marked hole on the LR7 angle frame. Secure it using the quick release pin. Connect the second LR7 to the front couplers. Turn the angle arm of the LR7 and line the “stack” hole (arrow) up with the desired angle hole in the angle frame. Continue this procedure for the remaining cabinets.

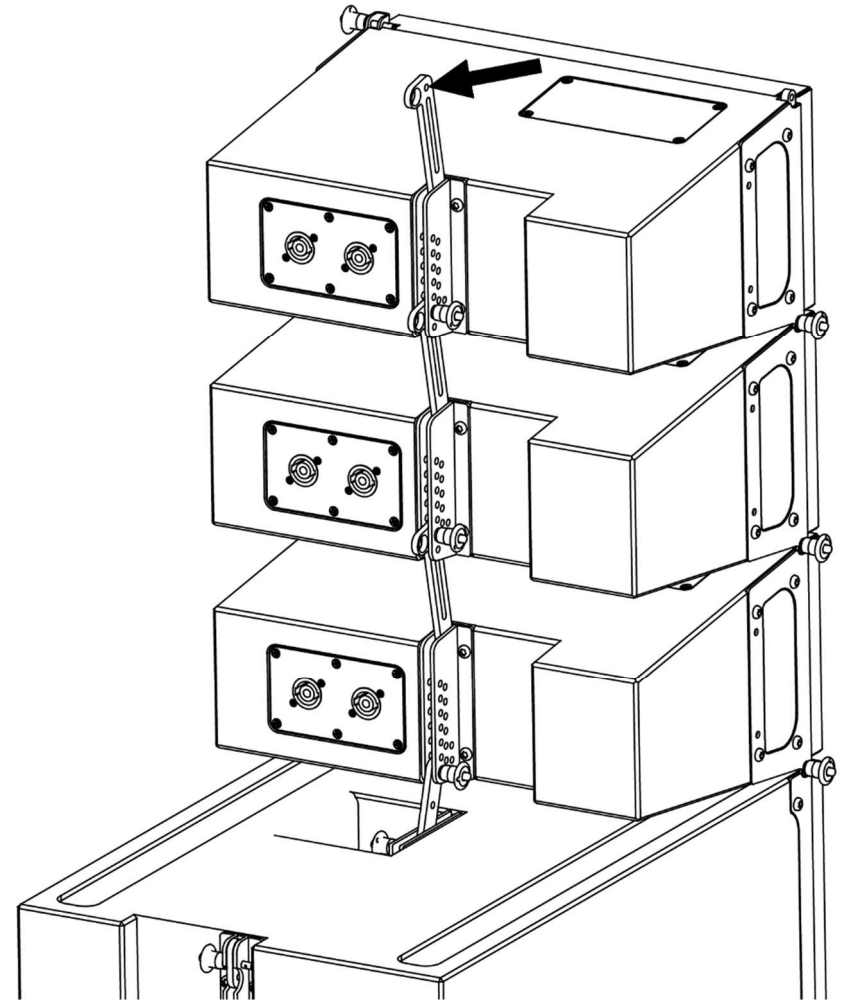

5. Array configurations

LR7 to BRK connection

A small array of LR7 cabinets can be connected to BRK3LR7 or BRK5LR7 with 4 quick locking pins. They have to align with the 2 parking holes on both sides of the LR7 cabinet. For ease of handling, it is advised to build up the array with individual LR7 cabinets.

As such an array will be a combination of "fly" and "stack" mode, it is advised to use stack mode for all cabinets.

Be aware that when the Centre of Gravity moves away from the mounting pivot point, both fastening knobs needs to be tightened up firmly.

In very challenging situations it is advised to use hexagonal bolts instead of the knobs. These can be mechanically tightened.

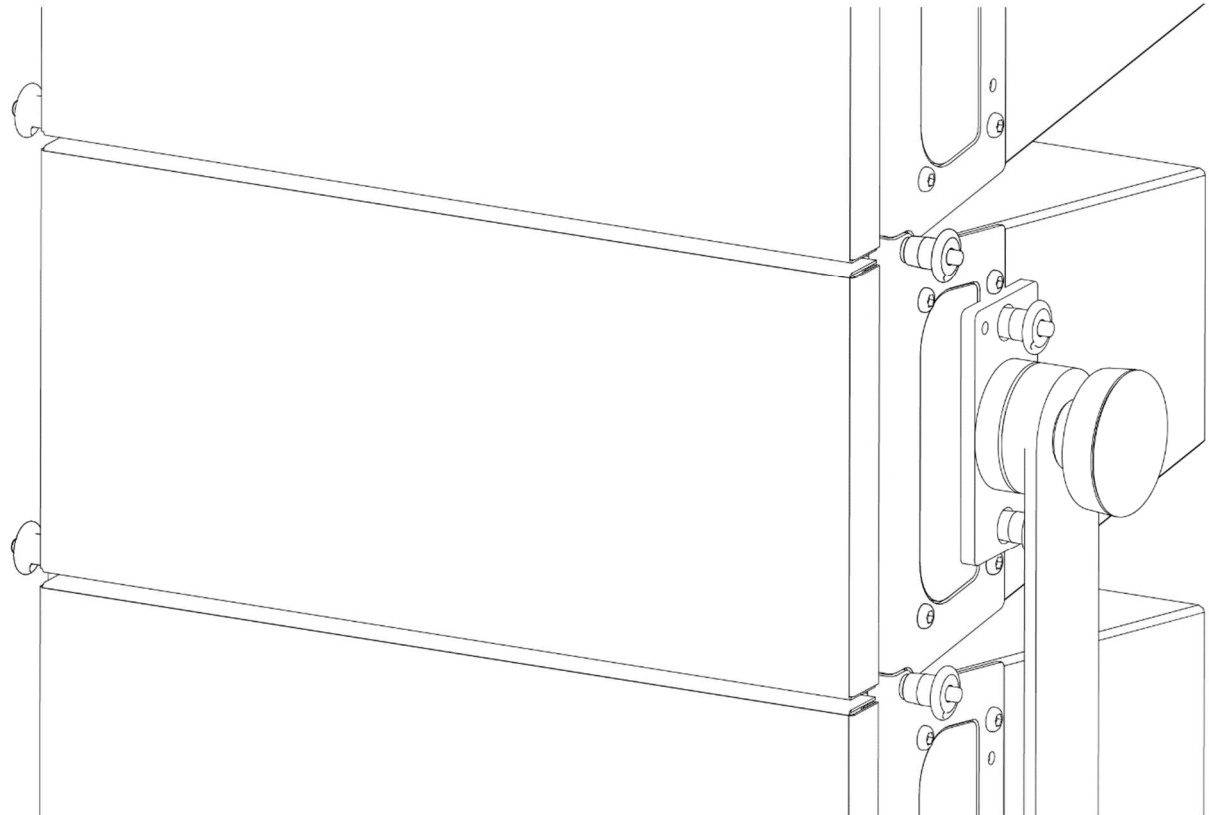

6. Service and support

Warranty

Summary

Alcons Audio BV warrants the original purchaser and any subsequent owner of each new Alcons product, for a period of six years limited from the date of the original purchase by the original purchaser that the new Alcons product is free of defects in materials and workmanship. Alcons Audio BV warrants the new Alcons product regardless of the reason for failure, except as excluded in this warranty. In order to obtain warranty, you must keep the original sales receipt to establish the exact date of purchase.

Items excluded from warranty

Warranty does not cover any product which has been damaged because of any misuse, accident, or negligence. Warranty also does not extend to a new Alcons product if the serial number has been defaced, altered or removed.

What we will do

Alcons Audio BV will replace defective parts and repair malfunctioning products, regardless of the reason for failure (except as excluded). Warranty work can only be performed at our authorized service centres, or at our factory.

Disclaimer

Alcons Audio BV is not liable for any damage to loudspeakers, amplifiers, or any other equipment that is caused by negligence, misuse or improper installation. Alcons Audio BV is not liable for any incidental damages resulting from any defect in the new Alcons product. This includes any damage to another product or products resulting from such a defect.

Alcons Audio BV reserves the right to change specifications without notice.

6. Service and support

Contact information

Mailing address:

Alcons Audio BV
De Corantijn 10
1689 AP ZWAAG
The Netherlands

Telephone:

+31 (0)229 283090

World Wide Web:

<http://www.alconsaudio.com>

E-mail:

info@alconsaudio.com



7. EC declaration of conformity

Alcons Audio BV
De Corantijn 10
1689 AP ZWAAG
The Netherlands

States that the following products:
LR7/ LR7B Rigging System

are in conformity with the provisions of the following EC directives and applicable amendments:

Machinery 2006/42/EC

and the national laws to enforce this directive,

National standards and technical specifications applied: *DIN EN ISO 12 100, DIN EN 1050, BGV C1*

provided the mounting components are unaltered/modified and in “factory-original” condition.

Established at Zwaag, the Netherlands,
December 1, 2022

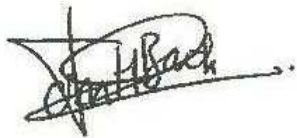

T.H. Back
Managing Director



Notes

