



# Cinemarray™

scalable line-source screen system

user's manual

Featured models:

CRA24  
CRA30



evolutionary audio solutions™

# Table of contents

---

1	Introduction	3
2	Important safety instructions and precautions	4
3	Installation	5
4	Rigging components	6
5	Array configurations	10
6	Service and support	13
7	CE declaration of conformity	15



# 1. Introduction

---

Dear customer,

Congratulations on your purchase of an Alcons Audio Cinemarray CRA series loudspeaker and thank you for your confidence in Alcons products. We are very honoured to welcome you to the growing family of Alcons ambassadors!

For your safety, please read the Important safety instructions and the precautions section before rigging a loudspeaker array.

## ***General features***

The CRA24 and CRA30 have the following features:

High-performance, line-array sound system for demanding cinema applications.

Multiple 4" pro-ribbon HF section with exceptional intelligibility and "throw".

Intuitive predictable linear response behavior and identical tonal balance at any SPL.

Non-compressed 1:1 HiFi-quality sound reproduction.

Maximum dynamic headroom reserve with up to 90% less distortion.

A unique seamless arrayability up to/beyond 20kHz.

Fully coherent pattern control in horizontal and vertical plane.

SIS™ pre-wired for very high system damping and further reduced distortion.

All Neodymium drivers for excellent performance-to-weight ratio.

Available with 120° or 90° dispersion in the non-coupling plane.

## ***CRA rigging features***

The cabinet is fitted with integrated mounting hardware, enabling angle-setting on the cabinets, The CRA24/ 30 rigging system has a working load limit of 3 cabinets stacked or flown

## ***Manual***

This manual is written in a compact and easy readable way. You can contact Alcons Audio for more in-depth information on different items or situations



## 2. Important safety instructions and precautions

---

### Read this manual

1. Follow all safety instructions as well as all warning messages.
2. Never incorporate equipment or accessories not approved by Alcons Audio.
3. Read all the related product information before using the system.
4. Work with qualified personnel for rigging the system.
5. Installation should only be carried out by qualified personnel who are familiar with the rigging techniques and safety recommendations stated in this manual.
6. Ensure health and safety during installation and setup.
7. All persons must wear protective headgear and footwear at all times. Under no circumstances personnel is allowed to climb into a loudspeaker assembly.
8. Respect the Working Load Limit (WLL) of third party equipment.
9. Alcons Audio is not responsible for any rigging equipment and accessories provided by third party manufacturers. Verify that the Working Load Limit (WLL) of the suspension points, chain hoists and all additional hardware rigging accessories is respected.
10. Respect the maximum configurations and the recommended safety level.
11. For safety issue, respect the maximum configurations outlined in this manual. To check the conformity of any configuration in regards with the safety level recommended by Alcons Audio.
12. Be cautious when flying a loudspeaker array. Always verify that no one is standing underneath the loudspeaker array when it is being raised or lowered. As the array is being raised, check each individual element to make sure that it is securely fastened to the adjacent element.
13. Never leave the array unattended during the installation process. As a general rule Alcons Audio recommends the use of safety slings at all times.
14. Be cautious when ground-stacking a loudspeaker array.
15. Do not stack the loudspeaker array on unstable ground or surface. If the array is stacked on a structure, platform, or stage, always check that the latter can support the total weight of the array. As a general rule, Alcons Audio recommends the use of safety straps at all times.

## 3. Installation

---

### Unpacking

Carefully open the shipping carton and inspect all the parts. Every Alcons product is thoroughly tested and inspected before leaving the factory and should arrive in perfect condition. If you find any damage, notify the shipping company immediately. Only you, the consignee, may initiate a claim for shipping damage. Be sure to save all packing materials for the carrier's inspection.



## 4. Rigging components

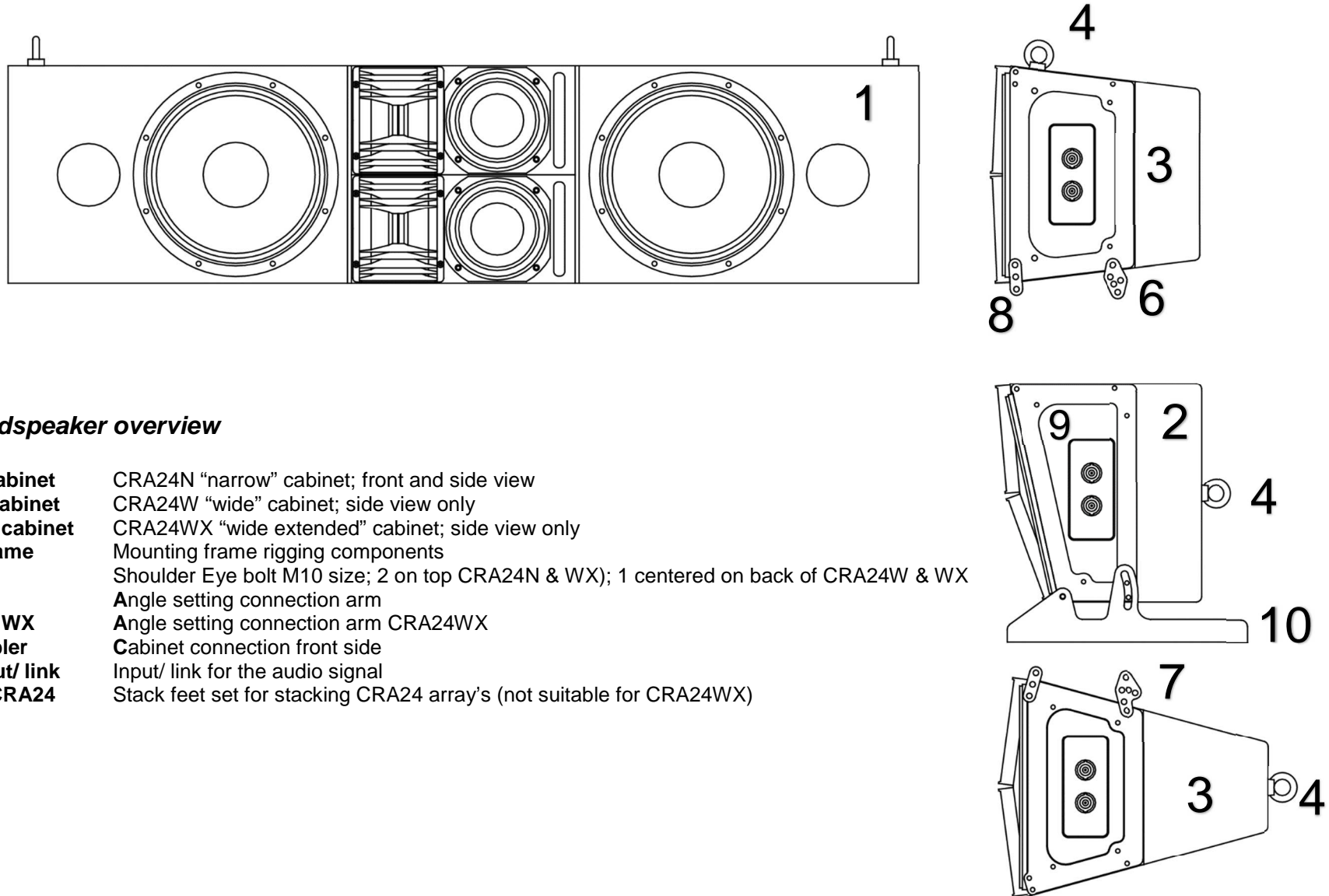

### CRA24 loudspeaker overview

- |                       |  |
|-----------------------|--|
| 1) CRA24N cabinet     | CRA24N “narrow” cabinet; front and side view   |
| 2) CRA24W cabinet     | CRA24W “wide” cabinet; side view only  |
| 3) CRA24WX cabinet    | CRA24WX “wide extended” cabinet; side view only                                      |
| 4) Rigging frame      | Mounting frame rigging components  |
| 5) Eye bolt           | Shoulder Eye bolt M10 size; 2 on top CRA24N & WX); 1 centered on back of CRA24W & WX |
| 6) Angle arm          | Angle setting connection arm   |
| 7) Angle arm WX       | Angle setting connection arm CRA24WX   |
| 8) Front coupler      | Cabinet connection front side  |
| 9) Signal input/ link | Input/ link for the audio signal   |
| 10) STCKFTCRA24       | Stack feet set for stacking CRA24 array's (not suitable for CRA24WX)                 |

## 4. Rigging components

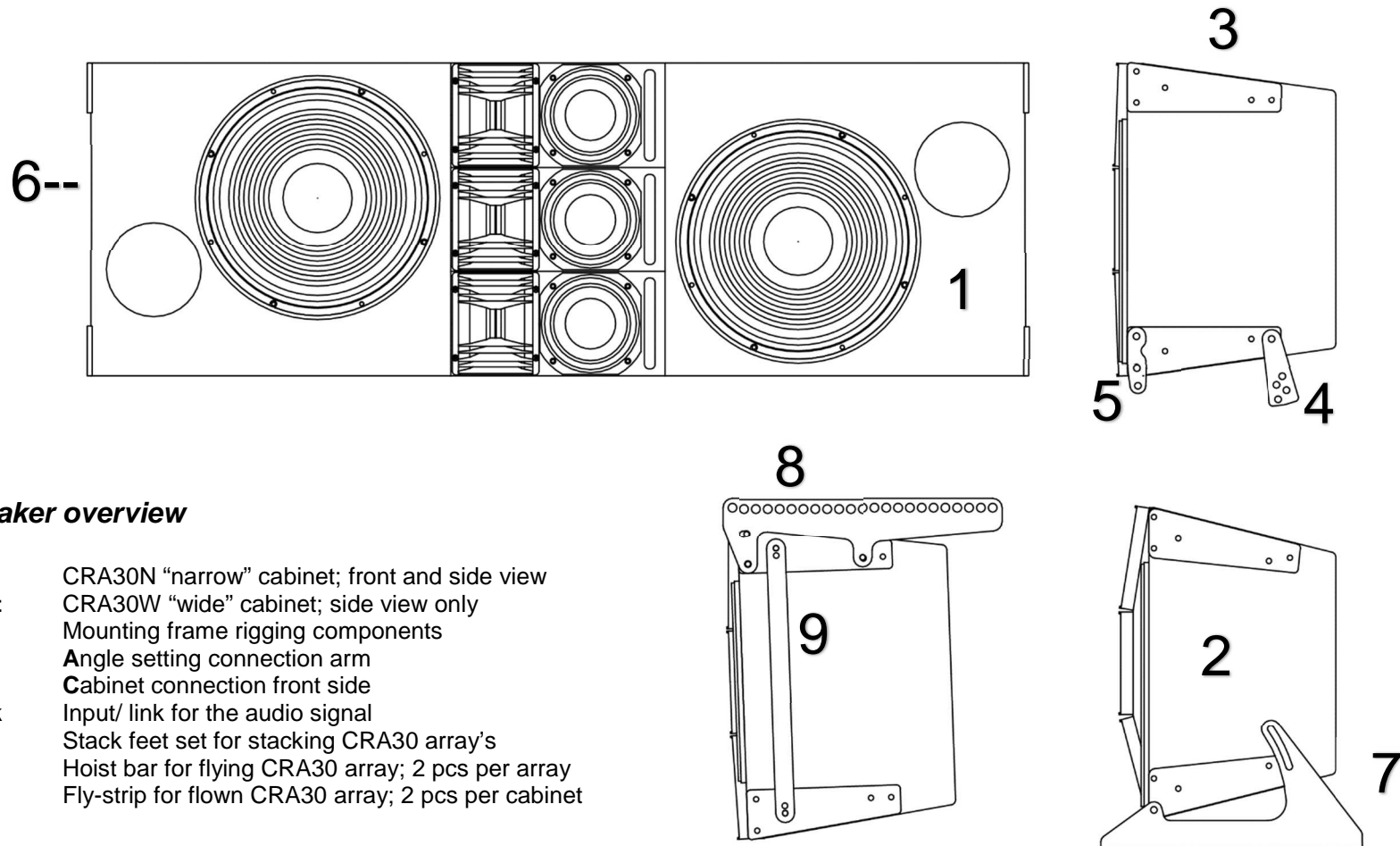

### ***CRA30 loudspeaker overview***

- |                              |  |
|------------------------------|--|
| <b>1) CRA30N cabinet</b>     | CRA30N “narrow” cabinet; front and side view       |
| <b>2) CRA30W cabinet</b>     | CRA30W “wide” cabinet; side view only              |
| <b>3) Rigging bracket</b>    | Mounting frame rigging components                  |
| <b>4) Angle arm</b>          | Angle setting connection arm                       |
| <b>5) Front coupler</b>      | Cabinet connection front side                      |
| <b>6) Signal input/ link</b> | Input/ link for the audio signal                   |
| <b>7) STCKFCRA30</b>         | Stack feet set for stacking CRA30 array's          |
| <b>8) HSTBRCRA30</b>         | Hoist bar for flying CRA30 array; 2 pcs per array  |
| <b>9) FLSTRPCRA30</b>        | Fly-strip for flown CRA30 array; 2 pcs per cabinet |

# 4. Rigging components

## Cabinet connections

The CRA24 and CRA30 cabinets are built with "narrow" and "wide" pre angled vertical coverage patterns:  
*All specified splay angles are between the adjacent HF wave-guides.*

**Fixed angles (A):**

- CRA24N 5°
- CRA24W 15°
- CRA24WX 15°

**Adjustable angles (B):**

- 0°, 5°, 6°, 9°

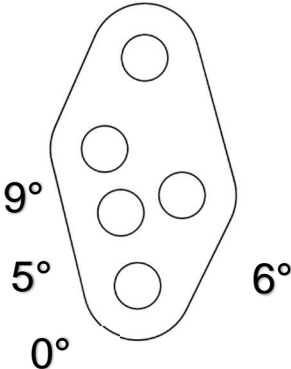

**Fixed angles (A):**

- CRA30N 2° + 2°
- CRA30W 9° + 15°

**Adjustable angles (B):**

- CRA30N-30W: 0°, 3°, 6°, 9°
- CRA30N-30N: 2°, 5°, 8°, 11°

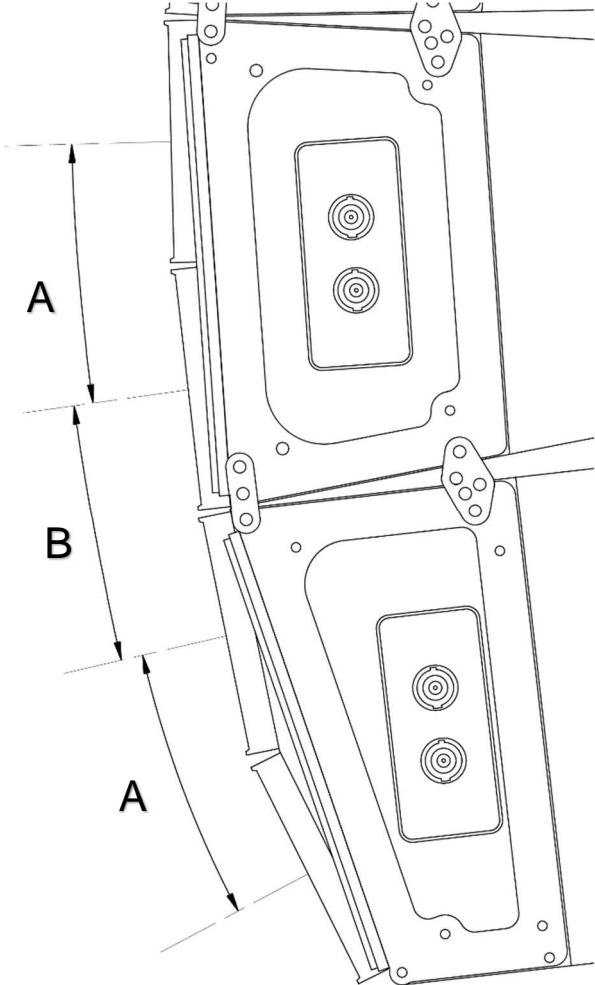
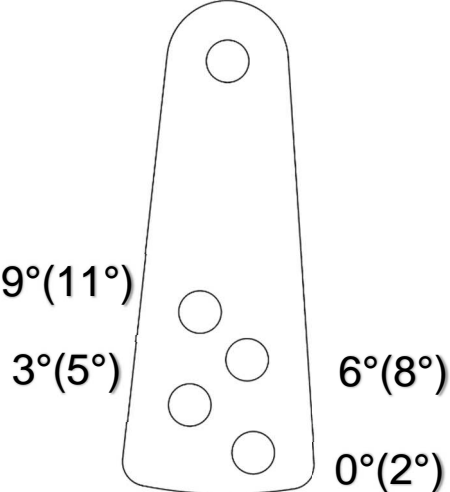

## 4. Rigging components

---

### Cabinet connections

The CRA24WX splay angle bar is suited for two combinations: CRA24N-CRA24WX and CRA24WX-CRA24WX  
*The combination CRA24W-CRA24WX is not possible. All specified splay angles are between the adjacent HF wave-guides.*

**CRA24N - CRA24WX Adjustable angles (B):**  
0°, 5°, 9°, 12°

**CRA24WX - CRA24WX Adjustable angles (B):**  
3°, 8°, 12°, 15°

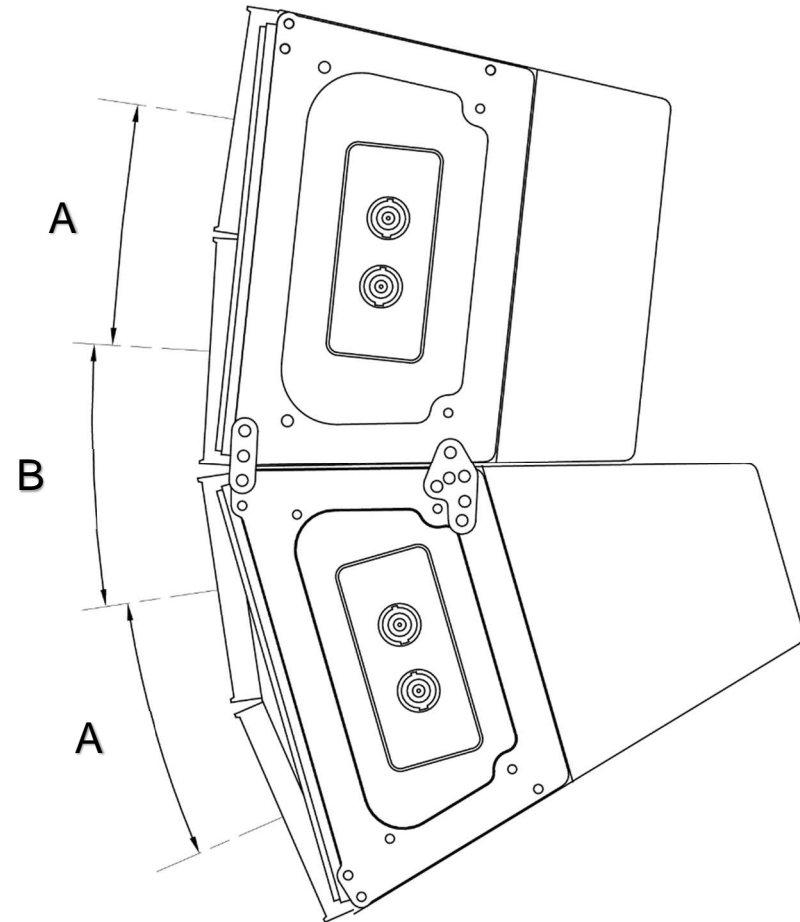
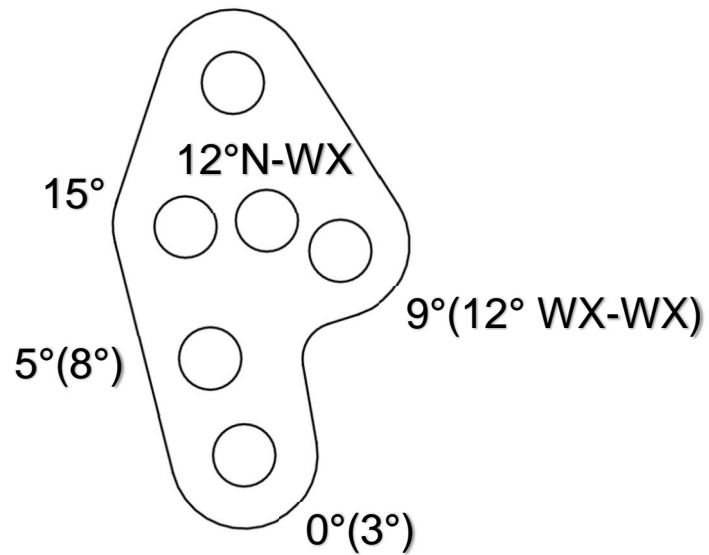

## 5. Array configurations

---

### ***CRA24 array assembling***

*The numbers in the text below, correspond with the CRA24 overview pictured earlier.*

The CRA24 system is preferably suspended from a truss girder or cinema screen frame. This is the default set-up. It is intended for indoor use only.

The system is scalable with a maximum of 3 cabinets:

- 1x CRA24N + 1x CRA24W
- 2x CRA24N + 1x CRA24W
- 1x CRA24N + 1x or 2x CRA24WX
- 2x or 3x CRA24WX

It is not possible to attach 2x CRA24W or CRA24W and CRA24WX under each other.

Mount two shoulder eye bolts (4) on the top CRA24N(WX) cabinet. They can be screwed in place when the two (top) cabinet screws have been removed.

Attach the front couplers (8) and angle arms (6/7) on bottom sides of the cabinet. Use the supplied M8 screws. They have a 8.8 strength class with a max. thread length of 12mm/ 0.47” Do not tighten up the screws at this moment. This gives more clearance when assembling the next cabinet. Hold the next cabinet under the first, **this is a two man job** and attach it to the front couplers. Do not let it hang under its own weight, because this will damage the HF horns! Make the angle arm connection, with the correct angle splay adjustment.

Repeat this mounting procedure with the last CRA24W(WX) cabinet. Mount the shoulder eye bolt on the centre rear mounting of this cabinet. Tighten up all screws.

Connect all cabling to the signal input panels (9) and ensure that the cable weight is supported by a dedicated cable suspension.

Hoist the assembled array up to the correct position and use the rear shoulder eye bolt to adjust the tilt angle of the array.

*The picture on the right shows a side view of an assembled 3pc CRA24 array.*

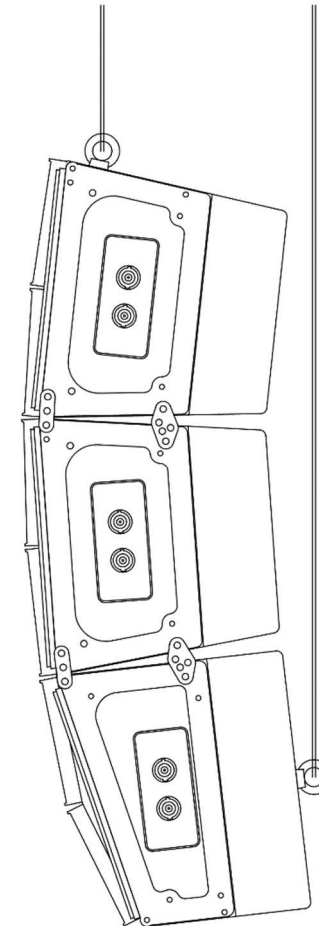

## 5. Array configurations

---

### **CRA24/ 30 array assembling**

*The numbers in the text below, correspond with the CRA30 overview pictured earlier.*

The CRA24/ 30 system can be stacked onto a cinema screen frame. This is the default set-up. It is intended for indoor use only.

The CRA30 system is scalable with 1x CRA30W + 1x CRA30N or 1x CRA30W + 2x CRA30N

It is not possible to attach 2x CRA30W to each other.

A stacked CRA24 system is scalable with 1x CRA24W + 1x CRA24N or 1x CRA24W + 2x CRA24N

Mount two CRA30 stack feet (7) at both sides of the CRA30W cabinet. They can be screwed in place with two M10x16 screws

For scratch protection, place a carton sheet on top of the CRA30W cabinet and place the next CRA30N cabinet on this sheet, with the front corners aligned. **This is a two man job.**

Attach the front couplers (5) and the angle arms (4) on bottom sides of the top CRA30N cabinet. Use the supplied M10 screws. They have a 8.8 strength class with a max. thread length of 16mm/ 0.63"

Do not tighten up the screws at this moment. This gives more clearance when assembling the next cabinet. Attach it to the front couplers. Make the angle arm connection, with the correct angle adjustment.

Repeat this mounting procedure with an optional second CRA30N cabinet. Tighten up all front coupler and angle arm screws. Tilt the complete array on the stack feet to the correct alignment (17° variable) and tighten these screws up firmly. The stack foot can be screwed to the screen frame for extra safety

Connect all cabling to the signal input panels (6) and ensure that the cable weight is supported by a dedicated cable suspension.

*The picture on the right shows a side view of an assembled stacked 3pc CRA30 array*

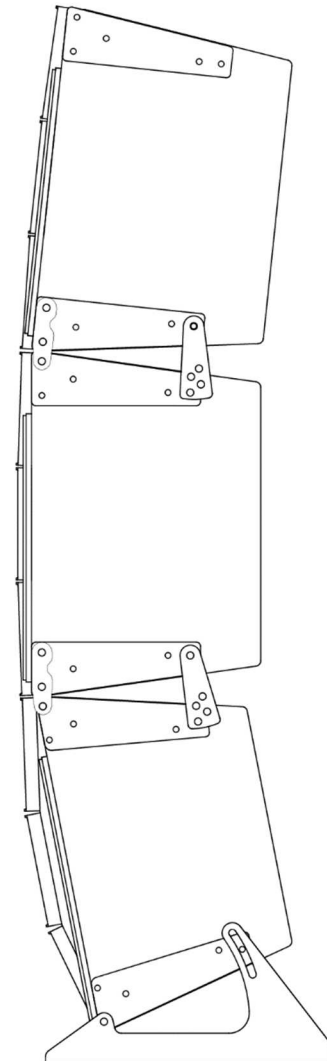

## 5. Array configurations

---

### **CRA30 flown array assembling**

*The numbers in the text below, correspond with the CRA30 overview pictured earlier.*

The CRA30 system can be flown from a cinema screen frame or Truss. This is an optional set-up. It is intended for indoor use only.

The system is scalable with 1x CRA30W + 1x CRA30N or 1x CRA30W + 2x CRA30N

It is not possible to attach 2x CRA30W to each other.

Mount two FLSTRPCRA30 strips (9) at both sides of the CRA30N (outermost holes) and W cabinet (inner holes). They can be screwed in place with two M8x45 screws. Attach two HSTBRCRA30 hoist-bars (8) onto the top CRA30N cabinet with M10x16 screws. The bar also fits on a CRA30W. The Hoist bar has 23x 14mm/0.55-in holes for 1,5T shackles. Use two hoists to raise the array. Use two steels/ chains on both hoist-bars for a stable hang and easy array-angling

Attach the front couplers (5) and the angle arms (4) on the top side of an underhung CRA30N or W cabinet. Use the supplied M10 screws. They have a 8.8 strength class with a max. thread length of 16mm/ 0.63"

Make the angle arm connection, with the correct angle adjustment.

Repeat this mounting procedure with an optional third CRA30 cabinet. Tighten up all front coupler and angle arm screws. Connect all cabling to the signal input panels (6) and ensure that the cable weight is supported by a dedicated cable suspension.

Hoist the completed array to the correct height and angle the array to the correct array tilt

*The picture on the right shows a side view of an assembled flown 3pc CRA30 array*

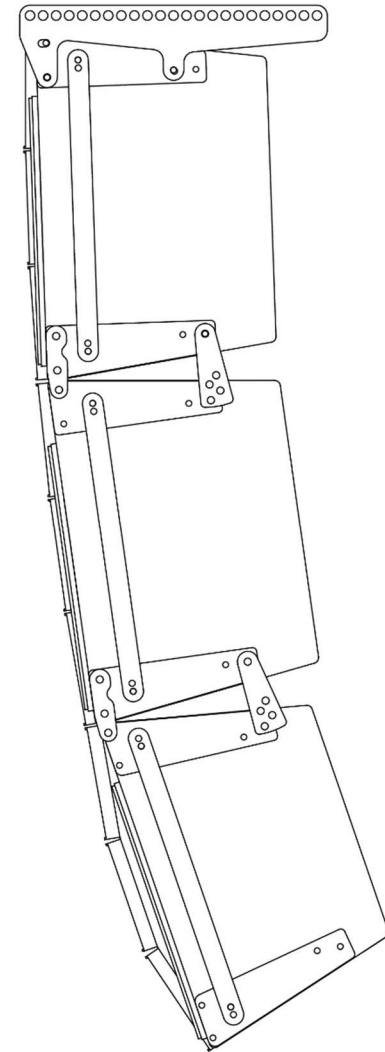

## 6. Service and support

---

### Warranty

#### Summary

Alcons Audio BV warrants the original purchaser and any subsequent owner of each new Alcons product, for a period of six years limited from the date of the original purchase by the original purchaser that the new Alcons product is free of defects in materials and workmanship. Alcons Audio BV warrants the new Alcons product regardless of the reason for failure, except as excluded in this warranty. In order to obtain warranty, you must keep the original sales receipt to establish the exact date of purchase.

#### Items excluded from warranty

Warranty does not cover any product which has been damaged because of any misuse, accident, or negligence. Warranty also does not extend to a new Alcons product if the serial number has been defaced, altered or removed.

#### What we will do

Alcons Audio BV will replace defective parts and repair malfunctioning products, regardless of the reason for failure (except as excluded). Warranty work can only be performed at our authorized service centres, or at our factory.

#### Disclaimer

Alcons Audio BV is not liable for any damage to loudspeakers, amplifiers, or any other equipment that is caused by negligence, misuse or improper installation. Alcons Audio BV is not liable for any incidental damages resulting from any defect in the new Alcons product. This includes any damage to another product or products resulting from such a defect.

Alcons Audio BV reserves the right to change specifications without notice.

## 6. Service and support

---

### Contact information

#### Mailing address:

Alcons Audio BV  
De Corantijn 10  
1689 AP ZWAAG  
The Netherlands

#### Telephone:

+31 (0)229 283090

#### World Wide Web:

<http://www.alconsaudio.com>

#### E-mail:

[info@alconsaudio.com](mailto:info@alconsaudio.com)



## 7. EC declaration of conformity

---

Alcons Audio BV  
De Corantijn 10  
1689 AP ZWAAG  
The Netherlands

States that the following products:  
CRA24/30 Rigging System

are in conformity with the provisions of the following EC directives and applicable amendments:

*Machinery 2006/42/EC*

and the national laws to enforce this directive,

National standards and technical specifications applied: *DIN EN ISO 12 100, DIN EN 1050*

provided the mounting components are unaltered/modified and in “factory-original” condition.

Established at Zwaag, the Netherlands,  
December 1, 2022



T.H. Back  
Managing Director



# Notes

---

