



# LR15

compact line-array module

user's manual

Featured models:

LR15

LR15B

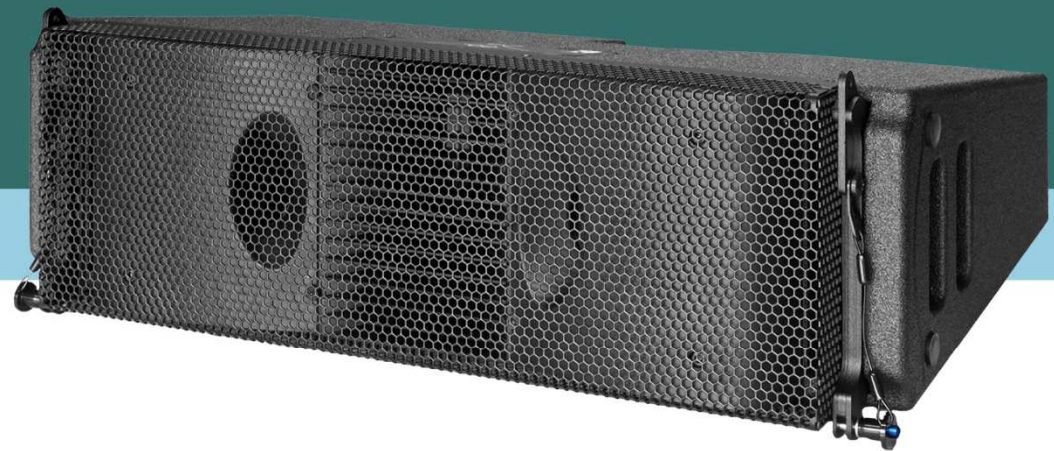

evolutionary audio solutions™

# Table of contents

---

1	Introduction	3
2	Important safety instructions and precautions	4
3	Installation	5
4	Rigging components	6
5	Array configurations	11
6	Service and support	24
7	CE declaration of conformity	26



# 1. Introduction

---

Dear customer,

Congratulations on your purchase of an Alcons Audio LR15 line-array loudspeaker and thank you for your confidence in Alcons products. We are very honoured to welcome you to the growing family of Alcons ambassadors!

For your safety, please read the Important safety instructions and the precautions section before rigging a loudspeaker array.

## ***General features***

The LR15 has the following features:

5" pro-ribbon HF section with exceptional intelligibility and "throw".

A unique seamless arrayability up to/beyond 20kHz.

Non-compressed 1:1 HiFi-quality sound reproduction.

Intuitive predictable linear response behavior and identical tonal balance at any SPL.

Maximum dynamic headroom reserve with up to 90% less distortion.

Fully coherent and symmetric pattern control in horizontal and vertical plane.

SIS™ pre-wired for very high system damping and further reduced distortion.

All Neodymium drivers for excellent performance-to-weight ratio.

## ***LR15 rigging features***

The trapezoidal cabinet is fitted with integrated mounting hardware, enabling angle-setting on the cabinets, without lifting the array, resulting in safer and faster set-up with minimal handling. The rigging system supports different kinds of array assembling and has a working load limit of 18x LR15 or 9x LR15B cabinets under 10:1 safety.

## ***Manual***

This manual is written in a compact and easy readable way. You can contact Alcons Audio for more in-depth information on different items or situations



## 2. Important safety instructions and precautions

---

### Read this manual

1. Follow all safety instructions as well as the warning messages.
2. Never incorporate equipment or accessories not approved by Alcons Audio.
3. Read all the related product information before using the system.
4. Work with qualified personnel for rigging the system.
5. Installation should only be carried out by qualified personnel who are familiar with the rigging techniques and safety recommendations stated in this manual.
6. Ensure health and safety during installation and setup.
7. All persons must wear protective headgear and footwear at all times. Under no circumstances personnel is allowed to climb into a loudspeaker assembly.
8. Respect the Working Load Limit (WLL) of third party equipment.
9. Alcons Audio is not responsible for any rigging equipment and accessories provided by third party manufacturers. Verify that the Working Load Limit (WLL) of the suspension points, chain hoists and all additional hardware rigging accessories is respected.
10. Respect the maximum configurations and the recommended safety level.
11. For safety issue, respect the maximum configurations outlined in this manual. To check the conformity of any configuration in regards with the safety level recommended by Alcons Audio.
12. Be cautious when flying a loudspeaker array. Always verify that no one is standing underneath the loudspeaker array when it is being raised or lowered. As the array is being raised, check each individual element to make sure that it is securely fastened to the adjacent element.
13. Never leave the array unattended during the installation process. As a general rule Alcons Audio recommends the use of safety slings at all times.
14. Ensure that the surface is suitable for ground-stacking a loudspeaker array.
15. Do not stack the loudspeaker array on unstable ground or surface. If the array is stacked on a structure, platform, or stage, always check that the latter can support the total weight of the array. As a general rule, Alcons Audio recommends the use of safety straps at all times.
16. When a loudspeaker assembly is deployed in an open air environment, wind can produce dynamic stress to the rigging components and suspension points. If the wind force exceeds 6 Beaufort scale, lower down and/or secure the loudspeaker array.



***The exclamation point within a triangle is intended to alert the user to the presence of important operating instructions in the literature accompanying the product.***

## 3. Installation

---

### Unpacking

Carefully open the shipping carton and inspect all the parts. Every Alcons product is thoroughly tested and inspected before leaving the factory and should arrive in perfect condition. If you find any damage, notify the shipping company immediately. Only you, the consignee, may initiate a claim for shipping damage. Be sure to save all packing materials for the carrier's inspection.

## 4. Rigging components

---

### *LR15 loudspeaker*

- |                       |  |
|-----------------------|--|
| 1) LR15 cabinet       | LR15 cabinet (shown)   |
| 2) Front coupler      | front couplers, lockable with quick release pin              |
| 3) Recessed grip      | recessed area in the cabinet for handling                    |
| 4) Pin angle setting  | pin determines the angle between the cabinets                |
| 5) Signal input/ link | input/ link for the audio signal                             |
| 6) Angle frame        | this frame holds features for the angle setting and coupling |



## 4. Rigging components

---

### *LR15B loudspeaker*

- |                     |  |
|---------------------|--|
| 1) LR15B cabinet    | LR15B cabinet shown                                    |
| 2) Coupler          | Rotatable couplers, lockable with quick release pin    |
| 3) Bar handles      | Handles in the cabinet ensure easy handling            |
| 4) Bottom connector | Connection with two holes, enabling a 2,5° splay angle |



## 4. Rigging components

---



### **GRD15**

The GRD15 enables the LR15 line-array modules to be flown and ground stacked. The grid can be suspended from multiple hoist positions on top of the grid or by means of a central “single pick-point” for smaller arrays; all points 14mm/0.55-in for 1,5T shackles. It has a mounting position and through hole for the Teqsas laser/ inclinometer. The GRD15 is certified for a safety-rating of 10:1, for eighteen (18) cabinets LR15.

### **GRD15B**

The GRD15B enables the LR15 line-array modules, and LR15B line-array bass modules to be flown and ground stacked. The grid can be suspended from multiple hoist options on top of the grid or with the central “single pick-point” bar for smaller arrays (all points 14mm/0.55-in for 1,5T shackles). The GRD15B is certified for a safety-rating of 10:1, for 18 cabinets LR15 and 9 cabinets LR15B \* on the hoist positions on top of the grid.

\* (or equivalent weight in mixed configurations)



## 4. Rigging components

---

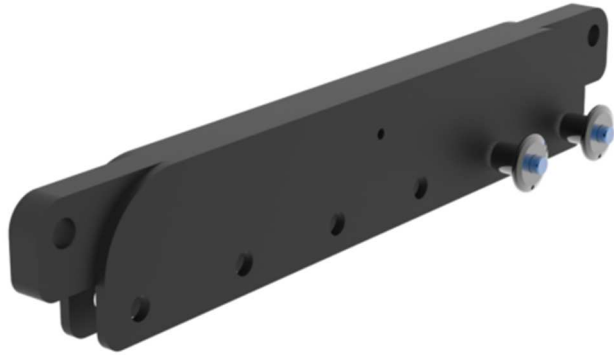

### **GRD18EXTBR**

This is a “sliding” extension bar, which can be attached on top of the GRD15 or GRD15B, to extend the leverage capabilities of the GRD15(B), with larger centre-of-gravity (COG) array off-sets. With the GRD18EXTBR mounted at the front side of the GRD15(B), the upward array tilt is extended; With the GRD18EXTBR mounted at the rear side of the GRD15(B), the downward array tilt is extended. The front and rear holes measure 14mm/0.55-in to facilitate 1,5T shackles. Always use both quick release pins for the GRD15(B)/ GRD18EXTBR connection.

### **BRK3LR15**

The BRK3LR15 is a base plate for a mini-array of up to three LR15 line-array modules on a stand. The base-plate is connected to the lowest cabinet with quick release pins. The base plate angle can be pre-set in three angles: -15°, 0°, 15° on a STMT stand mount.

On top of the base LR15, two other LR15 modules can be placed on top, maintaining full array functionality.

The BRK3LR15 is certified for a safety-rating of 10:1, for three (3) cabinets LR15.



### **CNVB1518**

The CNVB1518 conversion bracket is a transition frame to suspend a small LR15 array under an LR18 array for down-fill applications. It enables a maximum tilt angle of 10° between LR15 and LR18. The CNVB1518 is certified for a safety-rating of 10:1, for six (6) cabinets LR15.

## 4. Rigging components

---

### ***CPLNGGRD15***

The CPLNGGRD15 has a weight of 14 kg / 31 lb and is certified for a safety-rating of 10:1, for a front array of 9 (nine) cabinets LR15 and rear array for a rear array of 4 (four) cabinets LR15B on the hoist positions. (all points 14mm/0.55-in for 1,5T shackles).



### ***PNCLMP***

The PNCLMP can be used to suspend a LR15 array from a single point. The PNCLMP is attached with the Quick Release pin to a GRD15(B) pickpoint. The load can be attached to an overhead Truss or bar with a tube diameter of 51mm (2"). It can be horizontally adjusted and fixed. The max. allowed WLL is 250kg.

## 5. Array configurations

### Cabinet connections LR15

Array assembling can be done in two ways: Caterpillar style or Pre-rig style hoisting. This is determined by the available space, time or available parts. There are 12 user selectable logarithmic angles, which can be determined by the Alcons Ribbon Calculator™ simulation program. The angles are suitable for both caterpillar and pre-rig style array flying. The angle lay-out is pictured below left. The “P” indicates the position of the angle pin, when parking the angle arm. This bar can be rotated when the pin is removed from the “P” hole.

The picture on the right shows the angle frame (6). The angle arm has rotated out of its parking position, exposing also the finger control eye (A). It has a slot for default array building. The underlying hole (B) can be used in ground stack mode or when a array has to be made rigid. When this mode is used, the cabinets cannot compress.

*It is important to mention that the angle setting on the desired cabinet is done at the previous cabinet.*

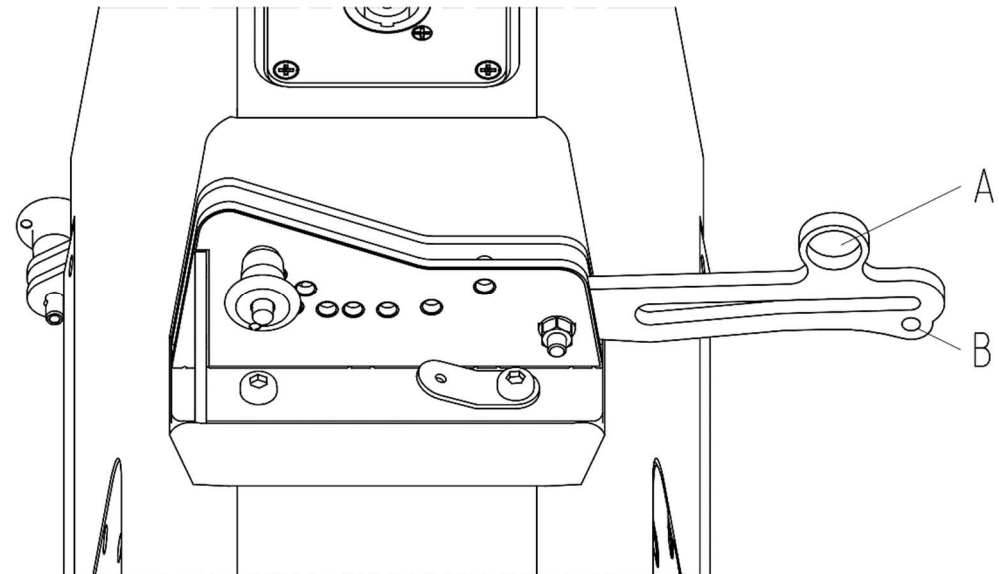
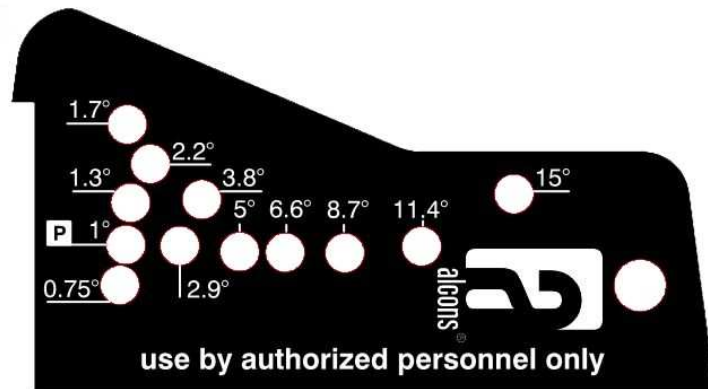

## 5. Array configurations

### Cabinet connections LR15B

LR15B has rotatable couplers, secured/ parked with a quick release pin. This pin is also used to make the connection to the GRD15B or the adjacent cabinet.

It is also possible to use the LR15B as a single standing subwoofer. It then stands on its long or short side with slider feet.

At the lower end of each bracket, there are two holes, which determines the splay angle  $0^\circ$  or  $2.5^\circ$ . This selection is made before hoisting. Only the front facing side needs to be selected. The back side is always set at  $0^\circ$ .

LR15B can be flown in a cardioid setup, using this method. There is a second NL4 Speakon connector mounted in the front grill.

**It is advised to use a separate cable hang for the speaker cables, as the NL4 (front + rear) Speakon connectors cannot take the entire cable weight.**

A second GRD15B (to enable the connection to a LR15 array), under a LR15B is connected with its top rotatable couplers to the  $0^\circ$  holes on the LR15B cabinet. This is also the setup for ground stacking LR15B+LR15.

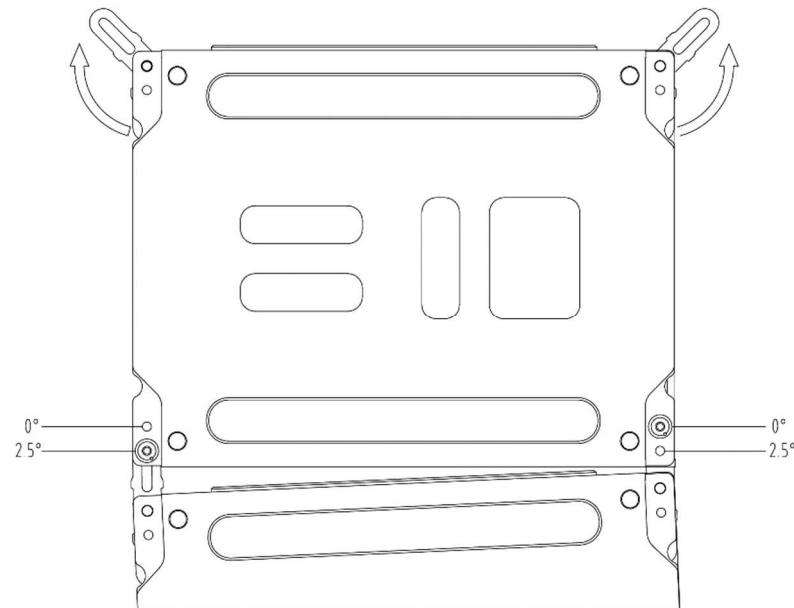

## 5. Array configurations

### GRD15 options

The GRD15 has multiple mounting options. The picture on the right shows the different pick-points for flying an array. The A1 & A2 marked points are the default hoist points.

It is possible to use one pick point from the A1 linear pattern. Use it only for max. 9x LR15

When hanging a 10-18 LR15 hoist points, use the **outermost** front and rear A1 pick points.

In case of a permanent installation, combine points A1 and 2x A2 for a stable 3-point hang. **Use 1,5T shackles at all times**

A3 indicates the mounting position of an angle inclinometer. It has a 4x ø4mm; 16.5mm x 108.8mm hole pattern for the Teqsas laser/ inclinometer.

Holes A4 can be used for a cable sling attachment.

The 2 holes A5 will hold the connection pin between the LR15 angle arm and GRD15

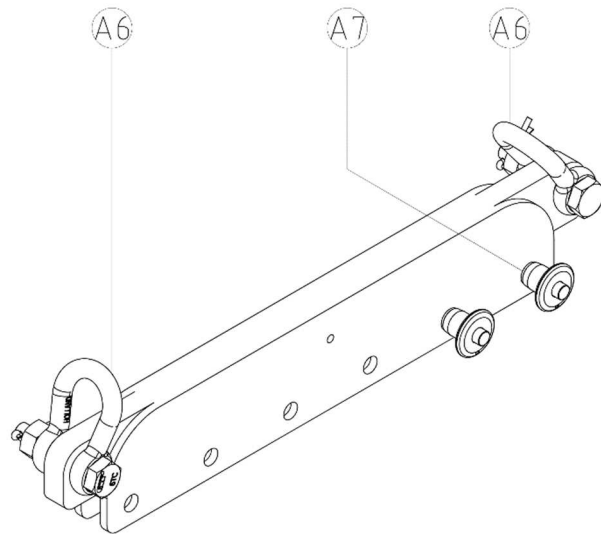
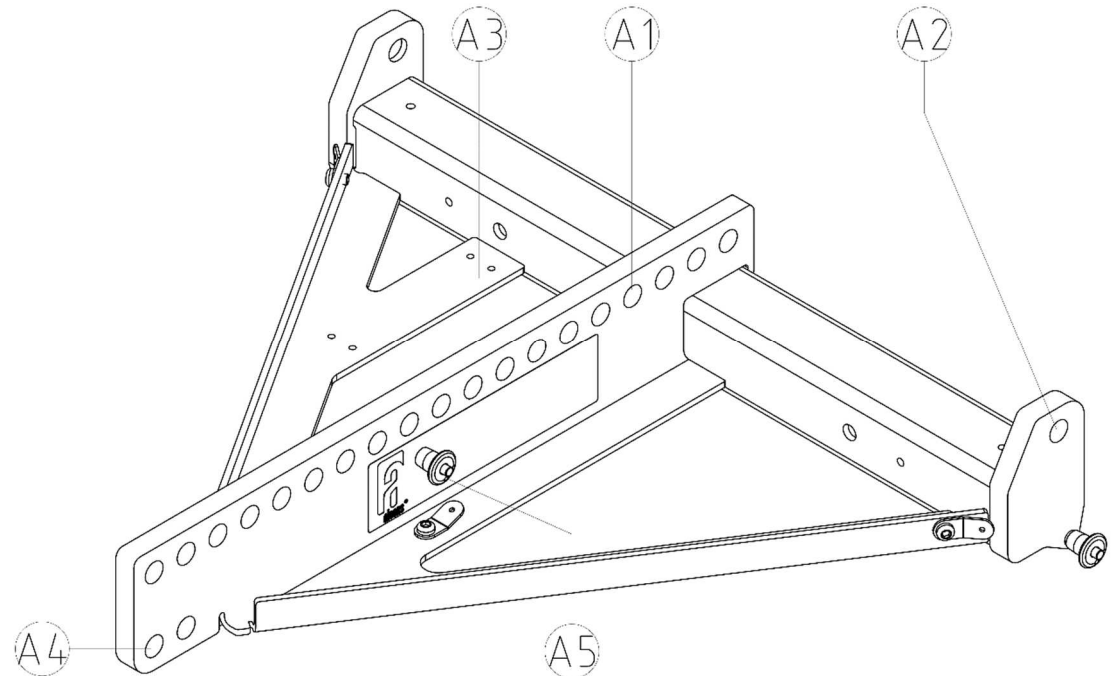

The picture on the left shows the **GRD18EXTBR** detached from GRD15(B). It has to be mounted with 2x A7 pins to the GRD15/ GRD15B A1 hole pattern, **at all times**. Create max. spacing between these 2 pins to spread the load on the GRD18/ GRD18B. A 1,5T "Green Pin" shackle should be used in both end holes A6.

## 5. Array configurations

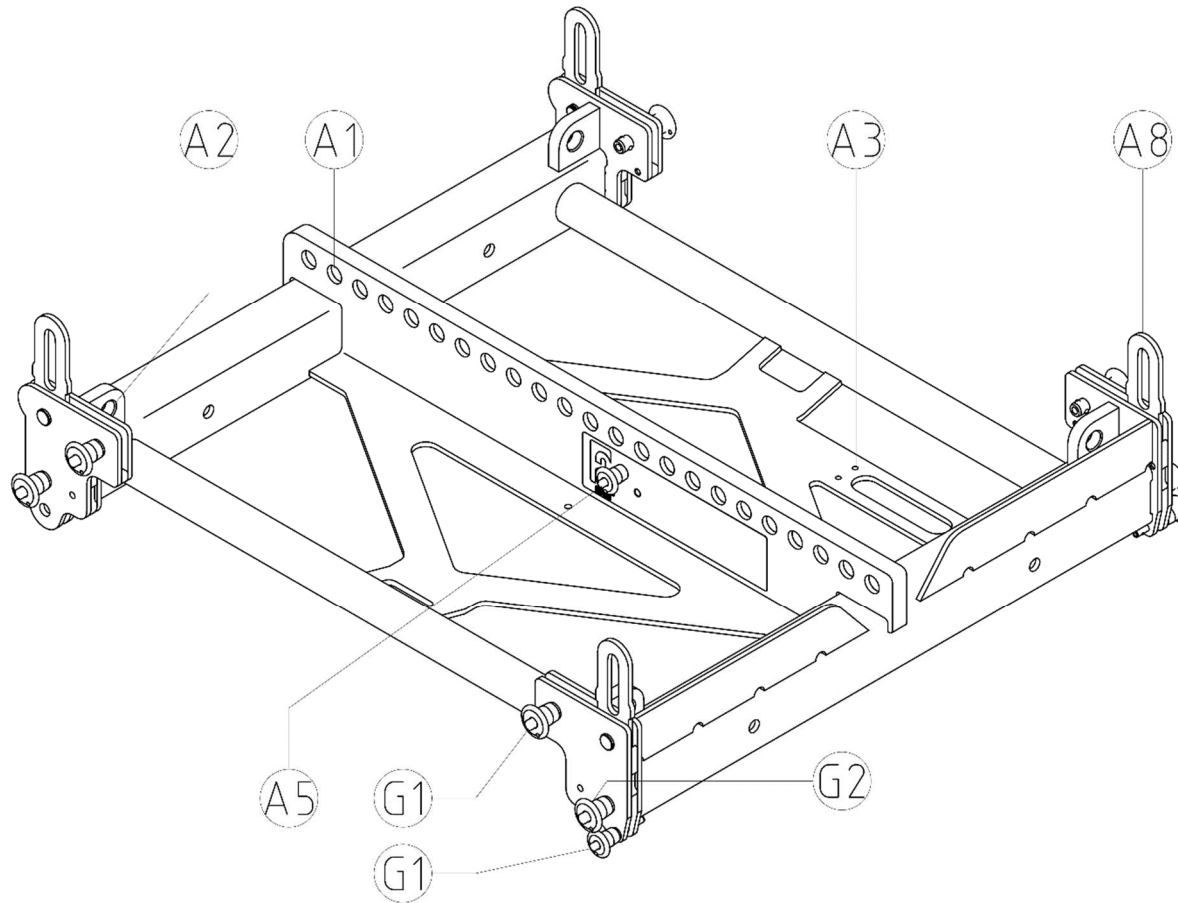

### GRD15B options

The GRD15B has multiple mounting options. The picture on the left shows the different pick-points for flying an array. The A1 & A2 marked points are the default hoist points.

It is also possible to use one pick point from the A1 linear pattern. Use it only for max. 9x LR15 or 4 LR15B cabinets

When hanging a 10-18 LR15 or 5-11 LR15B array with 2 hoist points, use the **outermost** front and rear A1 pick points.

In case of a permanent installation, combine points A1 and A2 for a stable 3 or 4-point hang. **Use 1,5T shackles at all times**

A3 indicates the mounting position of an angle inclinometer. It has a 4x  $\varnothing$ 4mm; 16.5mm x 108.8mm hole pattern for the Teqsas laser/ inclinometer.

The 2 holes A5 will hold the connection pin between the LR15 angle arm and GRD15B

A8 marks the angle arm which can connect to the bottom connection points on the LR15B and is pinned by G1. Turn the arms horizontally into their recesses and lock with the G1 pins, when using GRD15B as a top grid. G2 3/8" pin connects to the front couplers of a LR15B. G3 3/16" pin connects to the front couplers of a LR15

# 5. Array configurations

## GRD15 array options

The schematic picture below shows the possible array hang options a-d and stack arrangement e with LR15. The options also apply to GRD15B+LR15. As stated earlier, the array angles can be determined through the Alcons Ribbon Calculator™ simulation program.

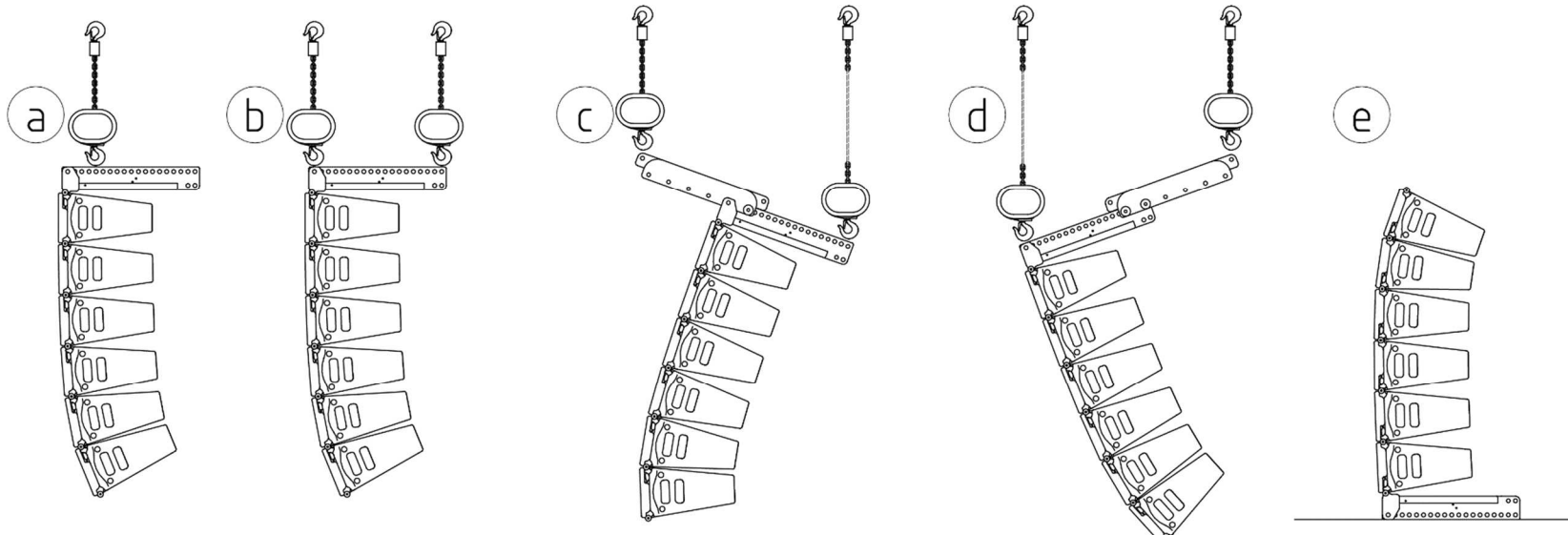

Max. 9x LR15

When ground stacking (e), ensure that the centre of gravity is well within the grid's base area.

The picture on the right shows the dimensions in mm of the GRD15 and GRD15B at the different extendable positions of the GRD18EXTBR extender bar.

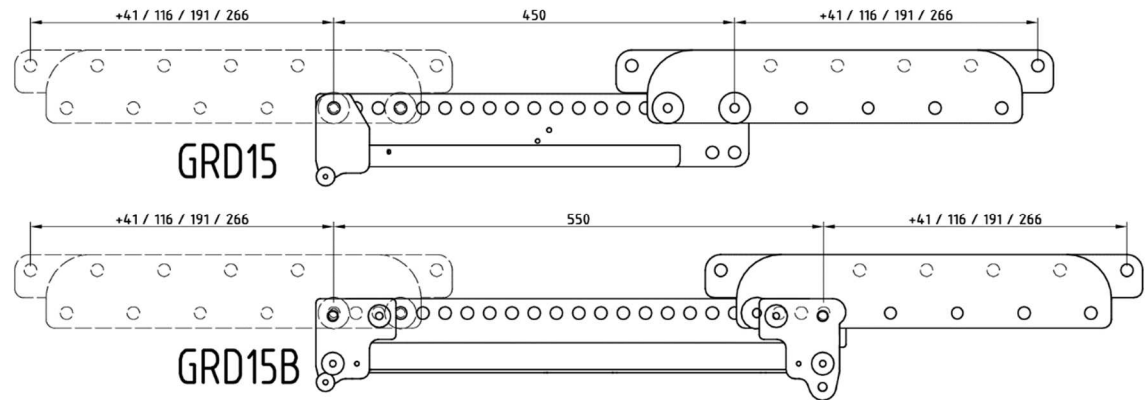

## 5. Array configurations

### GRD15B array options

The schematic picture below shows the possible array hang options f-h and stack arrangement i & j with LR15B and LR15. Attaching LR15 to LR15B (flying or stacking) requires a second GRD15B (h). This is due to the fact that the LR15 has 3 pick points and LR15B a 4 pick points set-up. LR15B can therefore be mounted 180° to the adjacent LR15B cabinet, creating a cardioid setup (f-g). Always attach each pick-point on GRD15B with 2 pins to the top couplers of the LR15B.

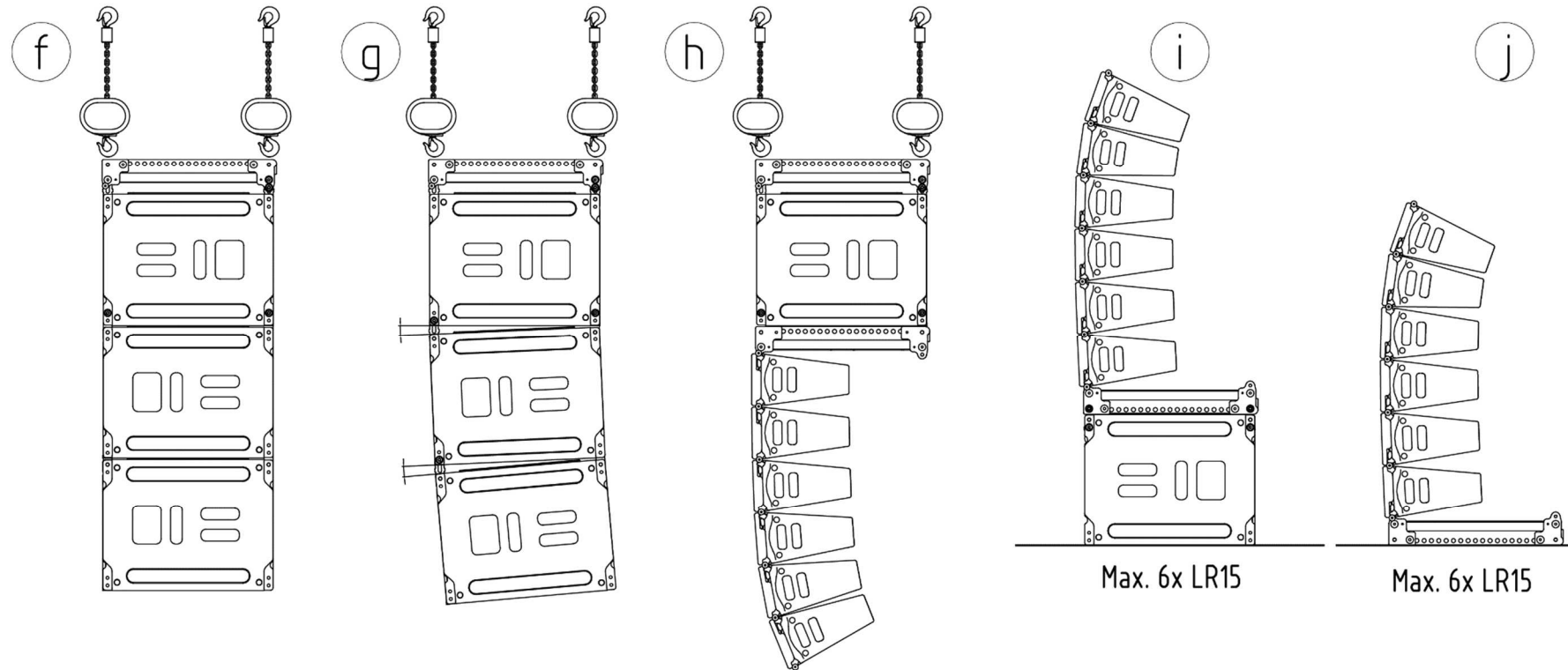

Placing the pin to the front bottom hole of the LR15B allows a 2,5° splay angle between the LR15B cabinets (g). This creates a curve in the LR15B array, which gives a better alignment to an adjacent, curved LR15 array.

## 5. Array configurations

---

### *LR15 transport and array building options*

There are two transport/ array building options available for LR15

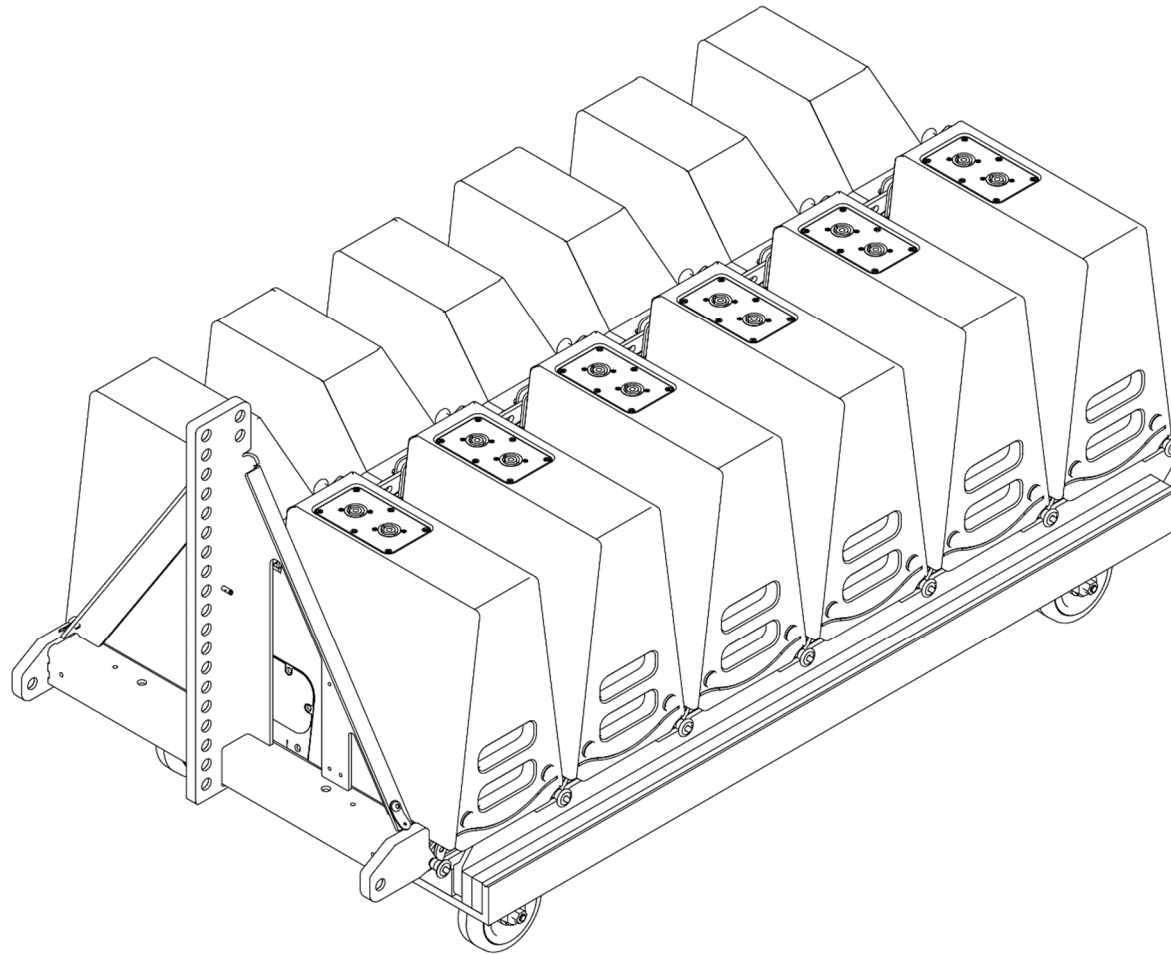

#### ***Caterpillar style:***

All LR15's are connected horizontally/ face-down on 3 or 6-pack dollies. Angle-setting can only be done in the area of the array that is in full compress state, from where LR15's are pulled up. FC3LR15CAT or FC6LR15CAT are used for this style.

***It is not possible to use LR15B with this building option.***

## 5. Array configurations

---

### *LR15 transport and array building options*

#### *Pre-rig style:*

All LR15(B) cabinets are connected vertically/ face-forward. This saves building space and enables pre-flight angle-setting. Tilting the already flown array on top of the pre-rigged array requires two motors, as the array needs to be dropped with the rear-side as low as possible, to be able to connect the rear latches. FC3LR15PRRG is used with this style (left). There is also a FC6LR15PRRG available for one 6 cabinet arrays. LR15B is transported on the PRRGLR15B; with a max. of 3 cabinets (right).

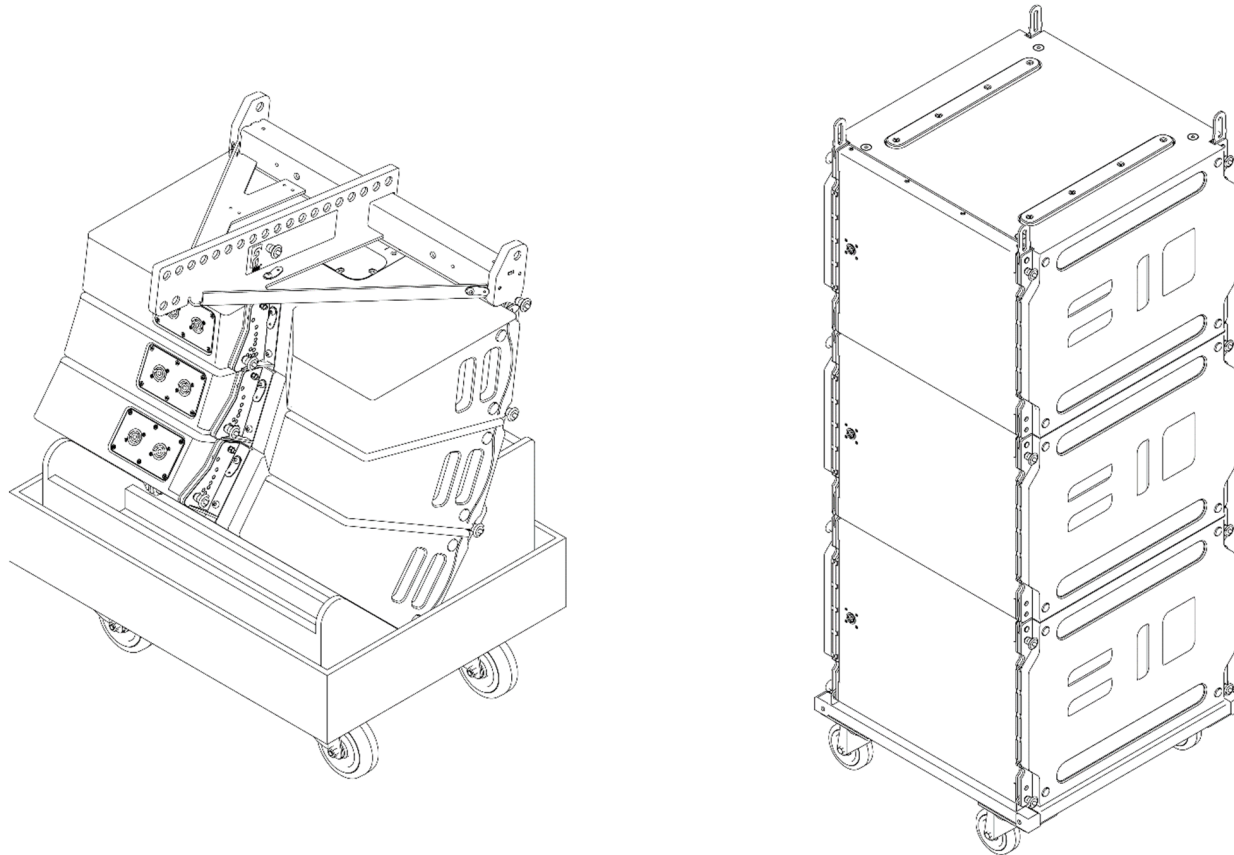

## 5. Array configurations

### Caterpillar style array assembling and hoisting

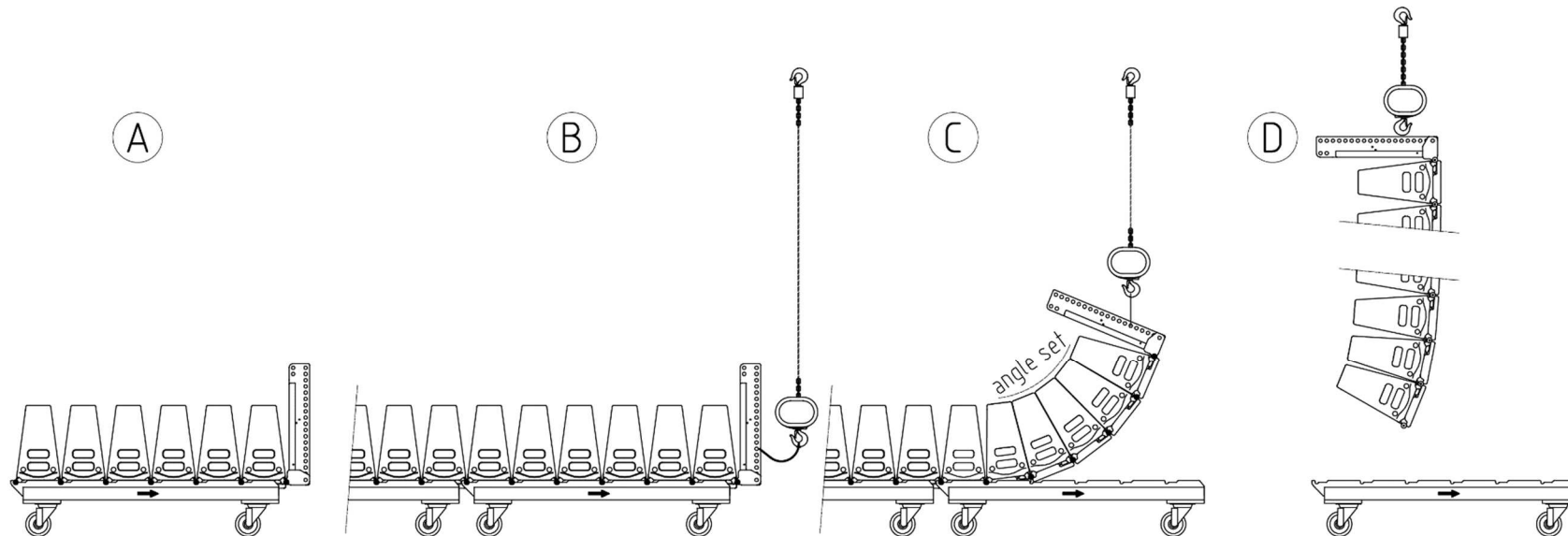

The numbers in the text below, correspond with the LR15 rigging components overview pictured earlier.

Shown above depicts array building, caterpillar style. Shown with 1 hoist, 1x GRD15 and 12x LR15 cabinets on 2x FC6LR15CAT flight-case dollies.

Start with attaching the GRD15 to the first cabinet on the FC6LR15CAT wheel dolly (A). Make sure that the following dolly is lined up correctly, with the arrow pointing towards GRD15. Attach the second dolly to the previous one, using the front couplers (B). Attach the hoist to the correct pick-point on the GRD15. Connect the necessary cabling to the signal input/ link (5) connectors. Use a sling from the grid for a tension free cable hang. Start hoisting until the first cabinets compress (C). Take the first dolly away for storage. Pull the angle setting pins (4) out and make the correct angles using the angle arm. These angles are determined by the Alcons Ribbon Calculator™ simulation program. Continue doing this until all angles are set. Raise the entire array from the last wheel dolly (D). Be aware that wheel dollies can ride away from the building area as the last module detaches.

### Landing the array caterpillar style

Ensure that the wheel dollies are correctly lined up under the array, with the arrows pointing to the front face of the array. Land the bottom pins of the front couplers into the recess of the dolly frame. When the bottom cabinets compress, take out the angle setting pins (4). Now the array can flatten out onto the wheel dollies. Continue doing this with all cabinets. When the complete array is stretched out on the ground, take off all cabling and pull out the front coupling pin between the first and second wheel dolly. Then return all angle arms in their parking positions. Now the FC6LR15CAT cases can be closed up and transported.

## 5. Array configurations

### Pre-rig style array assembling and hoisting

With this method of array building the angle setting can be done at the warehouse or on-site. Also build space is kept to a minimum. It is preferable to use two motor hoists, when building large arrays.

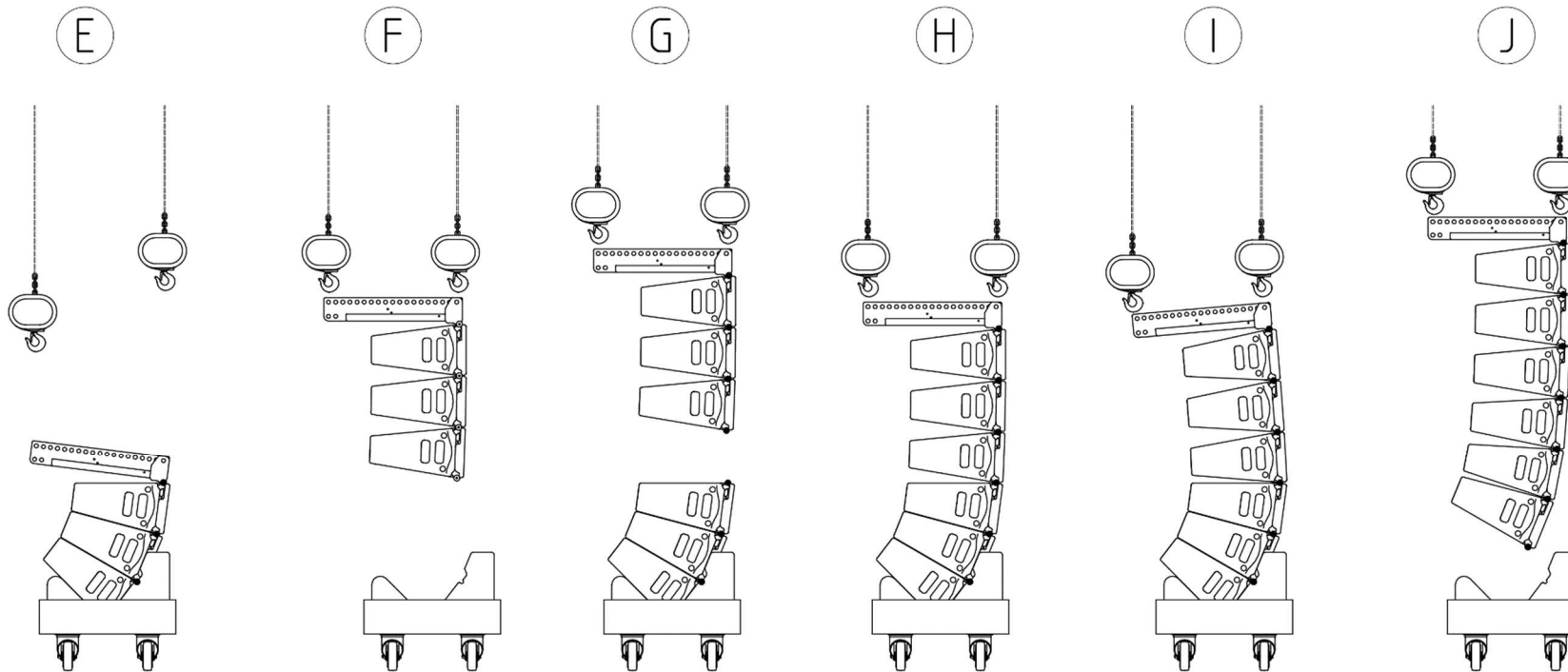

The numbers in the description below, correspond with the LR15 rigging components overview pictured earlier.



**Use slow speed or speed-controllable chain hoists. Avoid any form of excessive dynamic loading to the array assembly**

## 5. Array configurations

---

### ***Pre-rig style array assembling and hoisting***

This description features a 6 piece array connected to GRD15

*This procedure is also used when a LR15B section is used in the array under GRD15B*

Take off the top-head from the FC3LR15. Attach the GRD15(B) to the top cabinet and secure the hoist(s) to the correct pick-point of the array (E).

Ensure that the correct angles are set. As mentioned earlier, this is determined by the Alcons Ribbon Calculator™ simulation program.

Lift the 3 pcs array from the case wheel dolly and let it suspend above the next FC3LR15 transport case (F-G).

Lower the bottom cabinet couplers (2) over the top ones of the top cabinet. Adjacent cabinets can go  $-10^\circ$  in the vertical plane. See picture on the right. Pin the couplers with the corresponding quick release pins.

To make the inter 3pcs angle connection, lower the rear side of the array (I). The cabinet compression ensures that the angle can be set with the angle arm in the angle frame and lock with pin angle setting (4). The completed 6 piece array can now be hoisted and be complemented with all the cabling (J). Use a cable sling from GRD15(B) for a tension free cable hang. Make the correct total array angle with the dual hoists and go to the desired height.

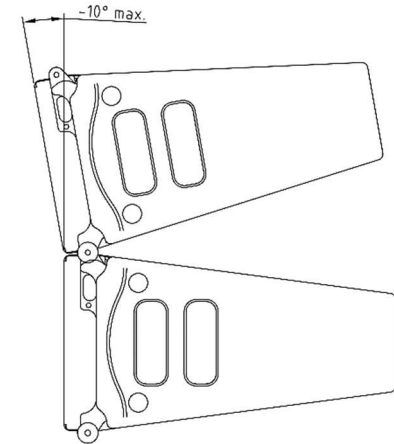

### ***Landing the array pre-rig style***

Ensure that the FC3LR15PRRG wheel dolly is correctly lined up under the array. Remove all cabling when that is possible. Land the bottom pins of the front couplers into the recess of the dolly frame. Let the bottom 3 cabinets compress, take out the angle setting pin (4), between the lower 3<sup>rd</sup> and 4<sup>th</sup> cabinet. Disconnect the front couplers and hoist the raised array a bit. Continue doing this with the last 3 piece array. Take off GRD15(B) and put all angle arms into their parking positions.

## 5. Array configurations

### Using CNVB1518

Attach the CNVB1518 frame to the LR18 cabinet front couplers(A) and angle frame connection pin(B). Lower the LR18 array onto the top LR15 module on the Pre rig. You can also mount individual LR15 cabinets to the LR18 array. Mount the LR15 front couplers to the front inside points of the CNVB1518 and pin them. Make sure that the LR15 angle arm of the lower, second cabinet is turned into the angle frame for the angles  $11.4^\circ$  and  $15^\circ$ .  $0.75^\circ$  and  $1^\circ$  can be made after the CNVB1518 is attached. Take out the CNVB1518 angle arm(1) and turn it down towards the LR15 angle frame. Feed the LR15 angle arm(3) through the CNVB1518 angle arm(1). Make the connection to the  $1.7^\circ$  angle hole of the LR15 angle frame and pin it(4). Secure the LR15 angle arm(3) to the CNVB1518 angle arm(1) with the long pin(2). Make further angle settings on the LR15 array, make the cable connections and start hoisting.

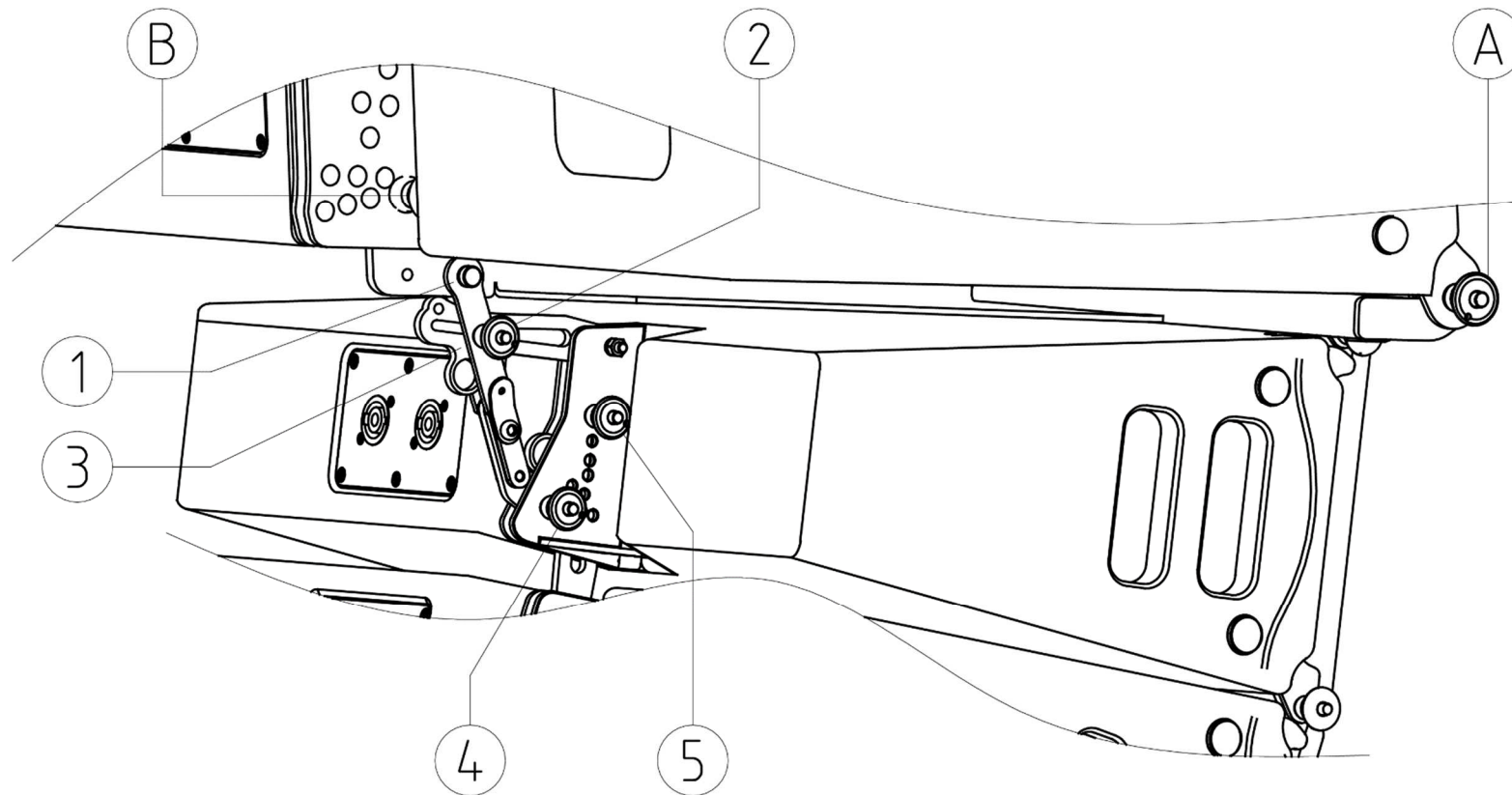

# 5. Array configurations

## Ground stacking

This description features a 6 piece ground stacked array. This is the maximum allowed number of cabinets in ground stacked mode with GRD15(B).



**Make sure that the array is assembled on a flat and stable surface**

Begin by positioning GRD15/ GRD15B in ground stack mode. Ensure that the centre of gravity will be well within the GRD15(B) base. This can be determined by the Alcons Ribbon Calculator™ simulation program.

Connect the first cabinet onto GRD15(B) with the front couplers (2). At the rear, take out the angle arm and connect it to the GRD15(B). You can choose between 0° and -2.7°. This is indicated on the GRD15(B) label (shown below). The 0° is paired to the slot end of the angle arm and -2.7° to the adjacent hole (arrow). Take out the pins of the front cabinet couplers (2) and place the second cabinet onto the first and connect them using the quick release pins. Take out the angle arm and line up **the hole** (arrow) with the correct angle in the angle frame (6). See picture on the right. Continue this procedure for the remaining cabinets.

**alcons**®

0° — stack  
0° — fly  
-2.7°

**GRD15**  
Max. WLL flown 300 kg (662 lb)  
Max. 18x LR15  
Max. 6 cabinets stacked on GRD15  
Use 1,5T shackles at all times.  
Rigging should be done by authorized personel only.  
Refer to rigging manual for safety / instructions.  
Always stay within the applicable Working Load Limits.

Serial number has been removed!

CE

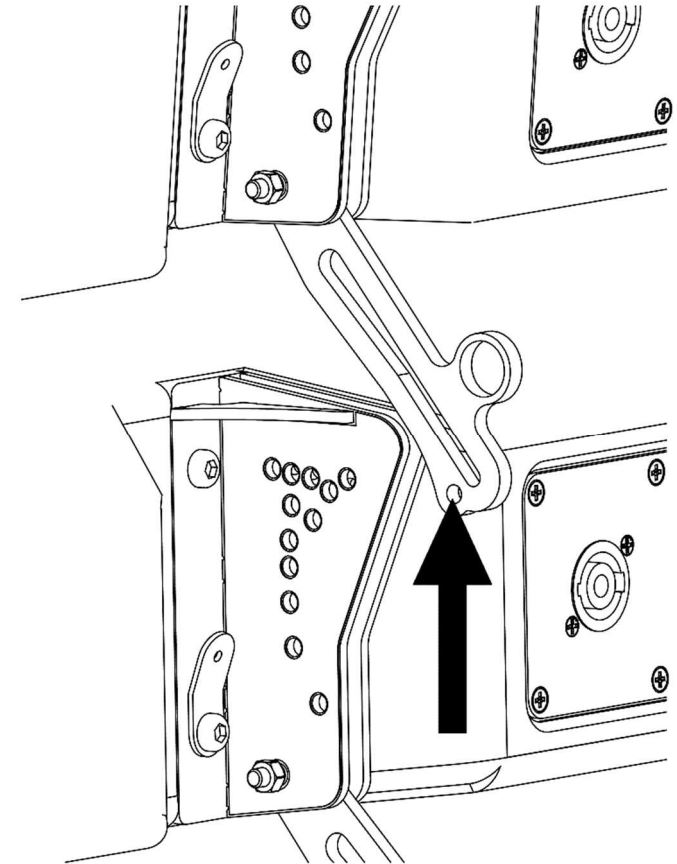

## 6. Service and support

---

### Warranty

#### Summary

Alcons Audio BV warrants the original purchaser and any subsequent owner of each new Alcons product, for a period of six years limited from the date of the original purchase by the original purchaser that the new Alcons product is free of defects in materials and workmanship. Alcons Audio BV warrants the new Alcons product regardless of the reason for failure, except as excluded in this warranty. In order to obtain warranty, you must keep the original sales receipt to establish the exact date of purchase.

#### Items excluded from warranty

Warranty does not cover any product which has been damaged because of any misuse, accident, or negligence. Warranty also does not extend to a new Alcons product if the serial number has been defaced, altered or removed.

#### What we will do

Alcons Audio BV will replace defective parts and repair malfunctioning products, regardless of the reason for failure (except as excluded). Warranty work can only be performed at our authorized service centres, or at our factory.

#### Disclaimer

Alcons Audio BV is not liable for any damage to loudspeakers, amplifiers, or any other equipment that is caused by negligence, misuse or improper installation. Alcons Audio BV is not liable for any incidental damages resulting from any defect in the new Alcons product. This includes any damage to another product or products resulting from such a defect.

Alcons Audio BV reserves the right to change specifications without notice.

## 6. Service and support

---

### Contact information

#### Mailing address:

Alcons Audio BV  
De Corantijn 10  
1689 AP ZWAAG  
The Netherlands

#### Telephone:

+31 (0)229 283090

#### World Wide Web:

<http://www.alconsaudio.com>

#### E-mail:

[info@alconsaudio.com](mailto:info@alconsaudio.com)



## 7. EC declaration of conformity

---

Alcons Audio BV  
De Corantijn 10  
1689 AP ZWAAG  
The Netherlands

States that the following products:  
LR15/ LR15B Rigging System

are in conformity with the provisions of the following EC directives and applicable amendments:

*Machinery 2006/42/EC*

and the national laws to enforce this directive,

National standards and technical specifications applied: *DIN EN ISO 12 100, DIN EN 1050, BGV C1*

provided the mounting components are unaltered/modified and in “factory-original” condition.

Established at Zwaag, the Netherlands,  
April 1th, 2023

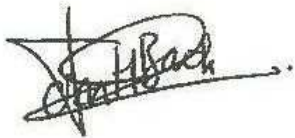

T.H. Back  
Managing Director



# Notes

---

